



Measurement of Capacitances Based on a Flip-Flop Sensor

Martin KOLLÁR

Department of Theoretical Electrotechnics and Electrical Measurement,
Technical University of Košice, Park Komenskeho 3, 041 01 Kosice, Slovak Republic
Phone: ++421-55-6022579, E-mail: Martin.Kollar@tuke.sk

Received: 4 August 2003 / Accepted: 22 September 2003 / Published: 23 September 2003

Abstract: This paper deals with a new type of system for measuring capacitances with the use of a flip-flop sensor controlled by a so-called fast-rise current control pulse. The theoretical considerations are compared with experimental results, and good agreement is reported. *Copyright © 2003 IFSA.*

Keywords: Flip-flop sensor, Capacitances measurement, Auto-compensative system

1. Introduction

The circuit in Fig.1 was introduced in [1] as a flip-flop sensor. The flip-flop sensor is part of a class of silicon sensors with a digital output. A standard flip-flop consisting from two transistors and two resistors (see Fig.1) is characterized by two stable states, 1 and 0.

One of the authors of the patent flip-flop sensor was Lian [1], who showed that a flip-flop sensor can be used for measuring non-electrical quantities and derived a formula for calculating the equivalent voltage of the flip-flop sensor controlled by a slow-rise control pulse. The principle of measurement is based on the measured non-electrical quantity breaking the value symmetry of the inverters relative to the morphological symmetry axis passing through points K and Z (see Fig.1).

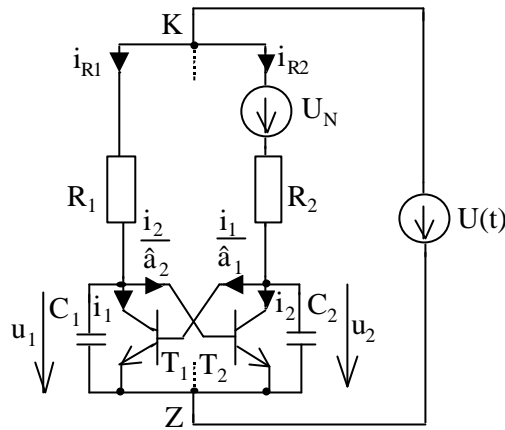

Fig. 1. Flip-flop sensor.

However measured quantity can be compensated by a voltage $U_N=U_{NE}$ in such a way that by repeated connection to source $I(t)$ the 50% state [1] is restored, so that the magnitude of the measured non-electrical quantity will be reflected in the voltage U_{NE} , which we will call the equivalent voltage. However, it is not necessary to stick to the custom of using sensorial elements, as shown in Fig.1.

It should be noted that in current control we also distinguish between pulses with a fast or slow-rise segment of the control pulse (see Fig.2).

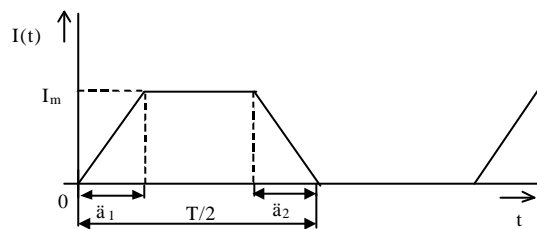

Fig. 2. Current control pulse.

Control with a fast-rise segment of the control pulse is characterized by the ratio I_m/\hat{a}_1 being such that the currents passing through the capacitors are not negligible compared to the transistor currents of the flip-flop sensors. This notion should be understood in its relative sense. In practice, this condition is satisfied if $\hat{a}_1, \hat{a}_2 \ll R_1 C_1$ and $\hat{a}_1, \hat{a}_2 \ll R_2 C_2$ at the same time.

The goal of this paper is to show that capacitors can be measured with the use of a flip-flop sensor in the structure of an auto-compensative system [2,3].

2. Equivalent Voltage

As described above, the asymmetry of the flip-flop sensor can be compensated by the equivalent voltage U_{NE} [1]. If we assume mismatches in the capacitances C_1, C_2 , then the formula for the equivalent voltage has the form [2,3]:

$$U_{NE} = \frac{R\Delta C}{2C} I_m, \quad (1)$$

where I_m is an amplitude of the current control pulse, $C_1 = C + \Delta C$, $R=R_1=R_2$, $C_2=C$ and $\Delta C / C \ll 1$.

The formula for calculation of equivalent voltage of flip-flop sensor controlled by vertical rise segments of the control pulse was first derived by Kollár [2,3].

3. Auto-Compensative System

An auto-compensative system is shown in Fig.3. R_1 and R_2 are the load resistors of the flip-flop and usually range from a few k to tens of k s. R_k is small resistor its value is normally two orders of magnitude smaller than R_1 and R_2 . The voltage u_0 is attenuated by the ratio R_0/R_k ($R_0 \gg R_k$) and is fed to flip-flop sensor. By adjusting u_0 , the asymmetry due to components in the flip-flop can be compensated, thus bringing the flip-flop sensor into 50% state [1]. The two outputs of the flip-flop are connected to comparators and the comparator outputs are connected to the integrator and reversible counter. The current of the flip-flop is switched on and off by a pulse generator. It is obvious that feedback is realized as analog, but reversible counter connected to the comparators enables to represent measured capacitance in digital form.

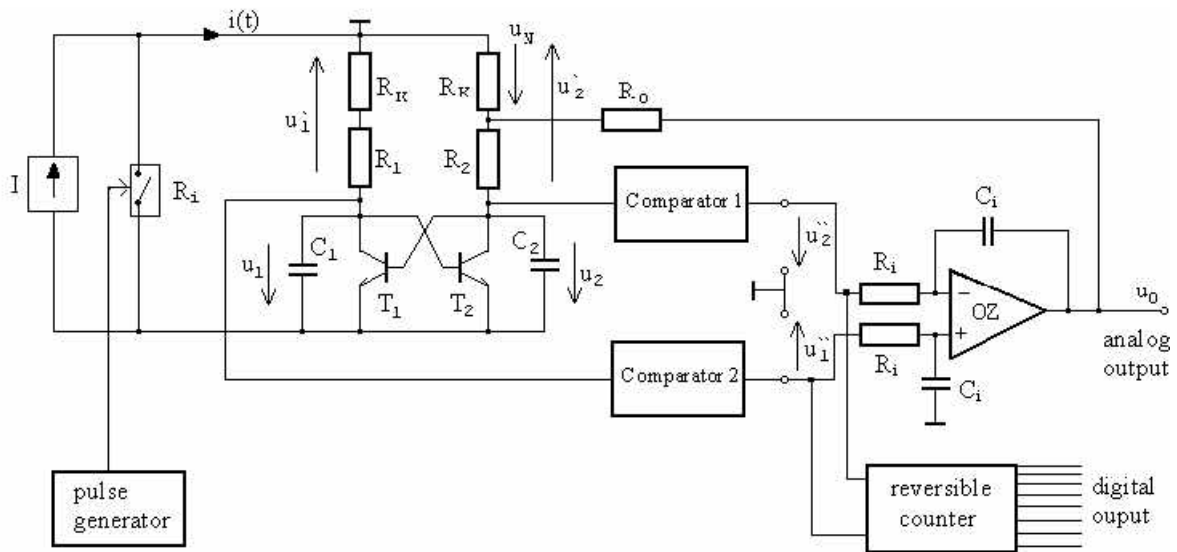

Fig. 3. Auto-compensative system.

Now suppose that $C_1 > C_2$. From the formula (1) it is obvious that $U_{NE} > 0$. After connection of the current generator voltage u_N increases, but if $u_N(t_1) > U_{NE}$, then beginning with this moment the situation starts to alternate which means the logical one will appear alternately at the output of the first inverter and then second inverter. Fig.4 expresses this fact. From the Fig.4 it follows that the measured capacitance will be reflected into the mean value U_{NS} of the symmetrizing voltage u_N .

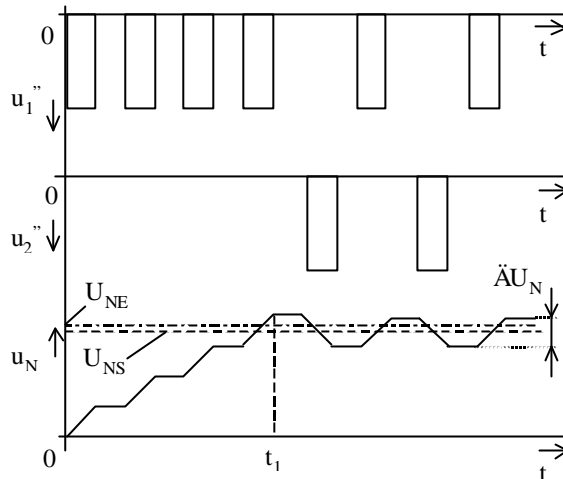

Fig.4. Principle of auto-compensative system functioning.

The principle of the auto-compensative system functioning is in more detail described in references [2,3].

4. Proposed Solution

Experimental circuit was made by surface montage technology. Fig.5 shows an experimental circuit. The parameters were set as follows $R=6.8k$, $R_k=10$, $R_0=1.8 k$, $C_i=10$ nF, $R_i=10 k$ and $C=530$ pF. The flip-flop sensor was controlled by a current pulse according to Fig.2, while $\ddot{a}_1=\ddot{a}_2=100ns$, $I_m=0.83$ mA and $T=100\grave{s}$.

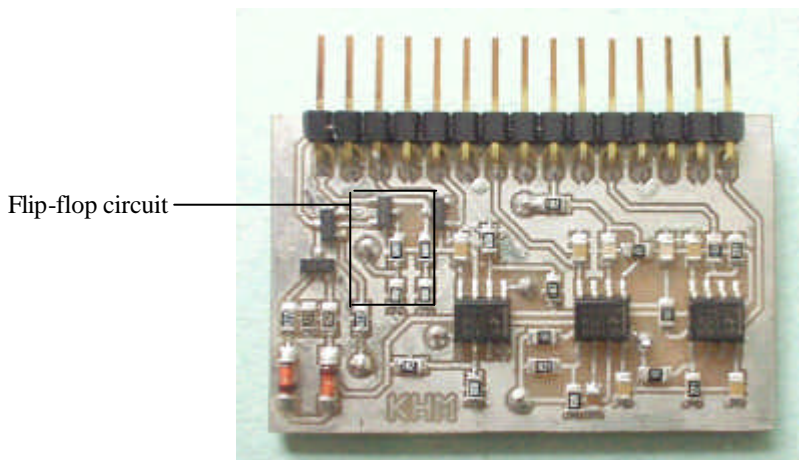

Fig. 5. A photography of experimental circuit.

An important parameter of the flip-flop sensor is offset voltage. Let the offset voltage depends on temperature changes, mismatches in resistances and capacitances, mismatches in transistor saturation currents and current gains. Assume that the two transistors are subjected to the same temperature and that the effect of mismatches in the transistor saturation currents and current gains and of mismatches in the resistances of the flip-flop is negligible compared with the effect of mismatches in the capacitances of the flip-flop sensor. The major cause of offset voltage is then due to mismatches in the capacitances of the flip-flop sensor. An asymmetry caused by mismatches in capacitances we will call a capacitive offset. A capacitive offset $\ddot{A}C_1$ can be compensated by a small DC voltage, or by a small capacitance to achieve $C_1=C_2$.

Now suppose that measured capacitance $\ddot{A}C_2$ is parallel connected to capacitance C_1 . The capacitance $\ddot{A}C_2$ can be calculated using formula [2,3]

$$\Delta C_2 = \frac{2U_{NE}C}{RI_m} - \Delta C_1, \quad (2)$$

where U_{NE} is equivalent voltage with offset. The formula (2) was derived through (1) under the condition that $\Delta C = \Delta C_1 + \Delta C_2$, where $\ddot{A}C_1$ represents a capacitive offset.

The idea to measure the capacitances with compensation of the offset was used in the experiment. First must be measured capacitive offset $\ddot{A}C_1$ and then measured capacitance $\ddot{A}C_2$ can be calculated using (2). As shown above, the principle of operation is based on the measured capacitance breaking the value symmetry of the flip-flop, but the equivalent voltage can compensate this. In this case, the asymmetry will be reflected in the number of pulses read by the reversible counter. The capacitance will be equivalent to the mean number of the pulses read. In the practical measuring, the number of pulses read was processed using microprocessor and measured capacitance was calculated using formula (2) in Lab VIEW.

5. Metrological Characteristics

To use the system in an industry application its metrological characteristics must be known. In accordance with norm IEC 770, Fig.6 shows achieved errors for the change input capacitance from 0.5 pF to 3.5 pF (up) and from 3.5 to 0.5 pF (down). Input capacitances were made from phone cable given distances [4] (see Fig.7), and measured by RLCG meter BM 590.

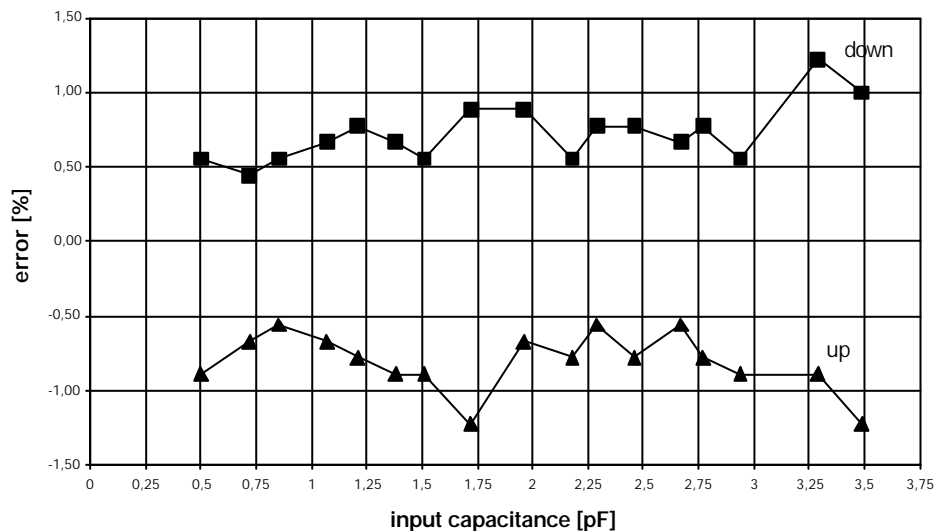

Fig. 6. Achieved errors for the change input capacitance up and down in percents from measuring range (3 pF).

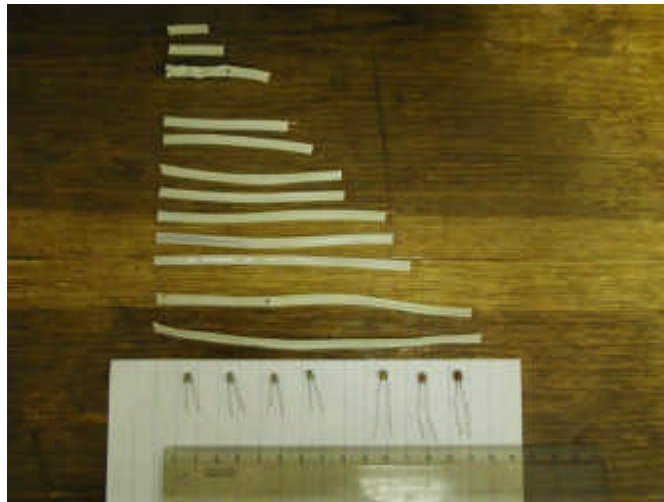

Fig. 7. Capacitances made from phone cable.

From Fig.6 it follows that maximal value of hysteresis is equal to 2,22 % for input capacitance 3,5 pF. The value of repeatability is equal to 0,0205% for input capacitance 2.75 pF.

6. Conclusions

In this paper, a new method, based on a flip-flop sensor, for measurement capacitances in range a few pF has been presented. Auto-compensative system with flip-flop sensor enables to set the equivalent voltage automatically. To measure a capacitance connected to flip-flop, pulses from inverters are processed in reversible counter. A number of the pulses read represents a measured capacitance $\ddot{A}C_2$. But the flip-flop has a capacitive offset. To avoid incorrect measurement, capacitive offset $\ddot{A}C_1$ must be measured. Then capacitance $\ddot{A}C_2$ to be measured can be calculated using formula (2) in Lab VIEW. Fig.8 shows photography of measuring system. Measuring range can be changed with the values of load resistors R , current amplitude I_m or capacitance C , respectively, but it has not been investigated in this paper.

Possibility to measure capacitances from range a few pF predetermines to use it in capacitive sensors.



Fig. 8. A photography of measuring system.

Acknowledgements

The work presented in this paper was supported by Grant of Ministry of Education and Academy of Science of Slovak republic VEGA under Grant No.1/9030/02.

References

- [1]. W Lian, Integrated silicon flip-flop sensor, *Ph.D. Thesis*, Technical University of Delft, The Netherlands, 1990.
 - [2]. M. Kollár, V. Špány, T. Gabaš, Autocompensative system for measurement of the capacitances, *Radioengineering*, Vol. 11, No. 2, 2002, pp. 26-30.
 - [3]. M. Kollár, *Smart Sensors Based on a Flip-Flop Circuits, Ph.D. Thesis*, Košice, August 2002, p. 90. (In Slovak).
 - [4]. M. Kollár, Formula for the Calculation of the Equivalent voltage of the Flip-Flop Sensor, *Electronics Letters*, Vol. 2, 2002, [http: www.electronicsletters.com](http://www.electronicsletters.com)
-