

## Reliability Research and Analysis of Sink Node in Wireless Sensor Networks

<sup>1,2</sup> Yongxian SONG, <sup>2</sup> Ting CHEN, <sup>1</sup> Yuan FENG, <sup>1</sup> Zijian DONG

<sup>1</sup> School of Electronic Engineering, Huaihai Institute of Technology,  
Lianyungang, Jiangsu, 222000, China

<sup>2</sup> School of Electronic and Information Engineering, Jiangsu University,  
Zhenjiang, Jiangsu, 212013, China  
Email: soyox@126.com

Received: 4 October 2013 / Accepted: 9 January 2014 / Published: 31 January 2014

---

**Abstract:** Node is the basic unit for the wireless sensor network, its reliability is the premise of ensuring network reliable operation, and due to sink node is taken as routing equipment of the network, the reliability of sink node is directly related to whether data could be reliably transmitted to the user. So it is necessary to improve the reliability of node data transmission. A kind of node reliability method was put forward on the basis of analyzing the structure features of hierarchical WSN and summarizing the fault sources of nodes in the paper, namely, the reliability of sink node was considered from two aspects of hardware and software, and it was improved by drawing lessons from the spare parts measure used to improve mechanical reliability and combing the retransmission mechanism adopted by soft fault. The reliability functional model was established on the basis of qualitative analysis of important parameter which has effect on node reliability. By using Markov status graph and probability analysis, quantitatively analyzing spare parts number and retransmission times influence on the reliability, and the quantitative relationships among retransmission times, communication time and energy consumption were built. Under the premise of the normal operation of Software-Hardware, in order to specific studied on node reliability, we are done experiments from three aspects of obstacle, transmission distance and transmit power, and test results are obtained by analyzing variation and mean of LQI. Experimental results shown that compared with normal sink node, the sink node in this paper could avoid the transient faults in communication link, thus it has stronger anti-interference ability, and larger packet reception rate while transmission distance is longer or transmit power is less. Copyright © 2014 IFSA Publishing, S. L.

**Keywords:** Wireless sensor network, Reliability, Sink node, Markov status graph, Fault sources.

---

### 1. Introduction

Network reliability is an important index to evaluate network performance, compared with wired networks, and the reliability in wireless sensor network (WSN) may encounter greater challenges. For wireless sensor network, due to communication bandwidth is narrow, and it often changes, it is easy to be influenced by terrain landform such as

mountains, buildings, the obstacles and the natural environment such as wind and rain lightning and so on, and all kinds of interference sources are filled with wireless channel, communication quality has fallen. In recent years, domestic and foreign scholars have done a lot of researches in the aspects of WSN reliability, Xu Wenyuan researched the antenna interference by using frequency hopping technology [1], in order to avoid congestion,

Muhammad Mahbub Alam et al. realized data reliable transmission by controlling the transmission rate [2]. But they improved the WSN reliability from the perspective of the fault sources, it can only reduce the specified fault sources that have influence on reliability of WSN, it can't be deal with unknown fault sources. Shoubhik Mukhopadhyay, et al. put forward the data reliability technology of model [3], the data forecasting model was established according to the time correlation, and real-time error was corrected with model. Although this method can rectify the transient fault of nodes and wireless communication links, but, in the field of some high real-time requirements industrial control, the connectivity was increased by redundant nodes in generally, when a hardware failure occurs, the data transmission will be interrupted, and there are also some disadvantages too.

In this paper, according to improve the reliability method of the machinery, the key components of sink nodes adopted spare parts measures, the functional reliability model was solved using the Markov state diagram and probability analysis method, and established the relationship between reliability of sink node and characteristic parameters, the quantitative analysis of the nodes reliability model was implemented, and the reasonable parameters were determined to ensure the reliability of sink node.

## 2. The Reliability Model of WSN Node

In wireless sensor network, there are all kinds of potential fault sources in sensor nodes or sink nodes, and they mainly composed of sensor failure, hardware failure and communication channel failure. Among them, the sensor faults was usually caused by nodes application environment or hardware transient faults, the sensor failure readings constantly caused with changes of environment (such as temperature, humidity, etc.), hardware deviation and calibration drift. Hardware failures mainly refer to permanent faults of hardware parts, and it can't be repaired by the software. Communication channel faults are usually caused by interference, obstacles and other forms of transient faults. Compared with the sensor nodes, due to the lack of sensing unit, sink node faults mainly compose of hardware failures and communication channel failures. Therefore, according to improve the reliability methods of the machinery, the key components of sink nodes adopted spare parts measures, to some extent, the robustness of hardware was enhanced. Communication instability problem was solved by retransmission mechanism, and the nodes reliability was improved too.

When sink node reliability was improved, the redundancy configuration and retransmission mechanism increased the node energy consumption and time delay in communication. Therefore, sink node reliability model of WSN was established by

taking  $K$  which is the number of spare parts and  $x$  which is the number of retransmissions as characteristic quantity, and considered two relationships, namely, sink node failure rate related with the number of spare parts which can determine state number of sink node when was in normal or fault and the number of retransmissions which can determine failure rate of the sink node internal module under the normal working state. The average energy consumption in data transmission and communication time restricted relationship with retransmission times  $x$ . Assume the following without loss of generality.

1) The spare parts can be repaired and repair to new.

2) The retransmission mechanism was applied to communicate between sensor nodes and sink nodes in subnets and between sink nodes in subnets, once the transmission was error, and the entire data frame was retransmitted.

3) Sink node energy consumption mainly considered sending and receiving energy consumption in communications, and process energy consumption and sleep energy consumption was not considered.

4) The network adopt TDMA non competitive wireless channel to distribute the mode of communication.

Model that represents by function is as follows.

$$\begin{cases} R = \varphi(K, x) \\ x = \phi(E, t_{avg}) \end{cases}, \quad (1)$$

where  $\varphi(K, x)$  means that spare parts number and retransmissions times have influence on reliability;  $\phi(E, t_{avg})$  reflect that sink nodes energy consumption  $E$  and communication time  $t_{avg}$  have influence on the number of retransmissions.

## 3. Reliability Analysis of Sink Node

It is the key to achieve functional  $\varphi(K, x)$  and calculate  $\phi(E, t_{avg})$  for quantitative analysis of the model, the state transfer process of sink node was analyzed and the solution was done by using Markov state diagram, and  $\phi(E, t_{avg})$  was done through the quantitative analysis which the energy consumption and the communication time have influence on the number of retransmissions. Markov state diagram method is the system description method based on a state changes, it has great flexibility and can be used to describe almost all dynamic system state transfer process, the key component redundancy configuration and status changes of sink node can transfer node state, so sink node reliability can be analyzed by Markov state diagram method.

We must first identify state change rules of each component in nodes by adopting Markov state

diagram to analyze reliability of sink node. In this article, the processor and the wireless transceiver that was easy to have fault within sink node realized modular, and the two parts were relatively independent and implemented redundancy configuration, so need to describe each module state change process. According to operation and dormancy of the processor unit and wireless transceiver module was opened or closed, and it will be defined as four working condition, namely, the normal operation, monitoring, dormancy and fault. The previous three were normal, the fault belonged to failure.

Sink node module state transfer principle made the following assumptions: when  $t=0$ , the main module in the sink that had  $K$  spare nodes was in normal working condition, the standby module 1 was in a monitoring state, and the remaining spare module was in a dormant state; when the normal operation module or the surveillance state module was failure, the standby module that was dormancy turn into the normal working state, the surveillance state; when only a module was fault, and abandoned the surveillance state, ensured the normal operation of module; only when each module was failure, the node was in an absorbing state, and was unable to work. Apparently, the intermediate state number between the initial state and the absorbing state was controlled by the spare parts number  $K$ .

Sink node state transfer process was analyzed by Markov state diagram, supposed that sink node had  $N_s$  states, the  $N_s$  states were the absorbing state of the nodes, and when the number of spare parts was  $K$  and the number of retransmissions was  $x$ , the reliability of sink node was as following.

$$R(t) = \varphi(K, x) = 1 - p_{N_s}(t), \quad (2)$$

where  $p_{N_s}(t)$  was probability that the sink node was in the absorbing state, and it concerned with  $K$  and  $x$ ,  $K$  decided to the number of the state  $N_s$  of sink node,  $x$  decided to fault rate  $f_1$  when the module was in normal working state.

Fig. 1 shows the sink node state transfer graph when  $K=2$ ,  $\mu$  was the repair rate,  $f_2$  was fault rate in surveillance state of the module, and  $N_s = 8$ .

The  $N_s$  changed by exponential growth when the spare parts number increased, that is:

$$N_s = 2^{K+1} \quad (3)$$

In the retransmission mechanism, the sender received ACK that was transmitted from receiver to confirm the frame information, and sure that information transmission was successful, otherwise repeat, so ACK transmission failure will lead to repeat [4].

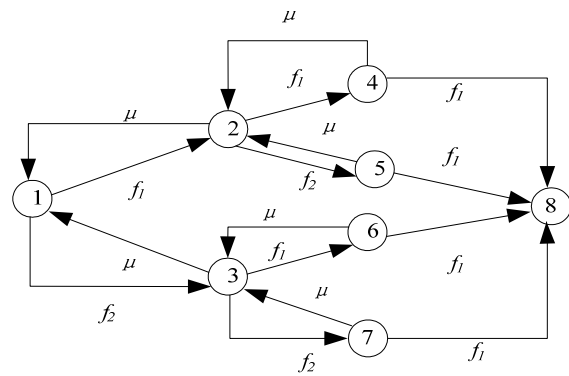

Fig. 1. The sink node state transfer graph when  $K = 2$ .

Supposed that bit error rate was  $p_{bit}$ , the length of data frame was  $l_n$ , the length of acknowledgement frame was  $l_m$ , and the number of retransmissions was  $x$ .

$$f_1 = (1 - (1 - p_{bit})^{l_n + l_m})^{(x+1)} \quad (4)$$

According to Markov theory,  $p_{N_s}(t)$  was obtained by the following equations.

$$\begin{cases} T = (T_{ij}(f_1, f_2, \mu))_{N_s \times N_s} \\ P(t + \Delta t) = P(t)T \end{cases} \quad (5)$$

where,  $T$  was the state transfer matrix of sink node,  $T_{ij}$  was transformation probability that transform from the  $i$  state to the  $j$  first state,  $\mu$  was the repair rate,  $f_2$  was fault rate when the module was surveillance state. Equation (5) is the steady state space equation for sink node, and  $P(t)$  was probability in various states of the sink node for the moment,  $(p_1'(t), p_2'(t) \dots p_{N_s}'(t)) = (p_1(t), p_2(t) \dots p_{N_s}(t)) \times [T - I]$  was obtained by equation (6) differential, the initial condition of node was,  $P(0) = \{1, 0, \dots, 0\}'$ ,  $p_{N_s}(t)$  can be solved when sink node was in the absorbing state by Runge-Kutta method.

#### 4. Retransmission Times Analysis

The energy consumption  $E$  of sink node mainly considered sending and receiving energy consumption in communications, due to the data sending energy was slightly higher than the receiving energy consumption in the same amount, in order to facilitate discussion, assume that the energy consumption of sending a data was equal to that of receiving a data, namely,  $\varepsilon_{TX} = \varepsilon_{RX} = \varepsilon \cdot p_{bit} \cdot l_n$ ,  $l_m$ ,  $f_1$ ,  $f_2$  and  $\mu$  setting methods were the same as above, and the transmission success probability of the

data frame was  $p(l_n) = (1 - p_{bit})^{l_n}$ , the received success probability of the confirmation frame was  $p(l_m) = (1 - p_{bit})^{l_m}$ .

The average power consumption of an information transmission failure was as following.

$$E_f = (1 - p(l_n)) \cdot [(l_n + l_m) \cdot \varepsilon] + p(l_n) \cdot (1 - p(l_m)) \cdot [(l_n + l_m) \cdot \varepsilon], \quad (6)$$

where  $(1 - p(l_n)) \cdot [(l_n + l_m) \cdot \varepsilon]$  was fault energy consumption that sent data frame at a time,  $p(l_n) \cdot (1 - p(l_m)) \cdot [(l_n + l_m) \cdot \varepsilon]$  was energy consumption that transmitted data frame correctly, the reception fault consumption energy of confirmation frame was as following.

$$E = (f_1)^{x+1} \cdot (x+1) \cdot E_f + \sum_{i=1}^{x+1} (f_1)^{(i-1)} (1 - f_1) \cdot [(i-1) \cdot E_f + (l_n + l_m) \cdot \varepsilon], \quad (7)$$

where  $x$  was the specified maximum number of retransmissions,  $i$  was the actual transmission times,  $(f_1)^{x+1} \cdot (x+1) \cdot E_f$  was the energy consumption that the transmissions were all failure for  $x+1$  times,  $\sum_{i=1}^{x+1} (f_1)^{(i-1)} (1 - f_1) \cdot [(i-1) \cdot E_f + (l_n + l_m) \cdot \varepsilon]$  was the energy consumption that the transmissions were all failure for  $i-1$  times and was successful at  $i$  time.

Due to adopt TDMA non competitive wireless channel distribution mode to communicate in network, the communication time  $t_{avg}$  was defined as the average time that the correct transmission of a data frame was required when the number of retransmissions was  $x$  [5], that is:

$$t_{avg} = t_T \cdot (1 + N_{avg}), \quad (8)$$

$$x(E, t_{avg}) = \begin{cases} E = (f_1)^{x+1} \cdot (x+1) \cdot E_f + \sum_{i=1}^{x+1} (f_1)^{(i-1)} (1 - f_1) \cdot [(i-1) \cdot E_f + (l_n + l_m) \cdot \varepsilon] \\ t_{avg} = [(l_n + l_m) / 250] \cdot \left[ 1 + \sum_{n=1}^x n \cdot f_1^n \cdot (1 - f_1) \right] \end{cases} \quad (11)$$

## 5. Design of Sink Node Hardware and Software

### 5.1. Hardware Circuit Design

Sink node in general consists of the processor, wireless communications and power supply and so on. The processor unit was responsible to control operation of sink node, store and process the data which other nodes transmitted; the wireless communication unit was responsible to communicate

where  $N_{avg}$  was a average retransmission times of a frame,  $t_T$  was a minimum time interval between two data frames that was successfully transmitted, and was the sum of a data frame transmission time and setting the retransmission time.

$$t_T = t_f + t_{out} = t_f + t_p + t_{pr} + t_a + t_p + t_{pr}, \quad (9)$$

where  $t_f$ ,  $t_{pr}$ ,  $t_p$  and  $t_a$  were the data frame transmission time, processing time, propagation delay, the acknowledgement frame transmission time respectively. Due to the speed of single chip microcomputer was very fast, so the processing time can be ignored. Propagation delay was the time that the electromagnetic wave spent on spreading a certain distance in the channel, however, the propagation rate of electromagnetic wave in free space was the speed of light, so the propagation delay can be ignored too, namely,  $t_T \approx t_f + t_a$ .

Data frame length was  $l_n$ , confirming the frame length was  $l_m$ , wireless sensor network data transmission rate was  $c = 250kb/s$ , so  $t_T \approx t_f + t_a = (l_n + l_m) / 250$ . The  $N_{avg}$  is determinated as:

$$N_{avg} = \{1 \cdot P(i-1=1) + 2 \cdot P(i-1=2) + \dots\} = \{1 \cdot f_1 \cdot (1 - f_1) + 2 \cdot f_1^2 \cdot (1 - f_1) + \dots\}, \quad (10)$$

where  $P(i-1=1)$  was probability that the number of retransmissions of a frame was one,  $P(i-1=2)$  probability that the number of retransmissions of a frame was twice.

Based on the above analysis, we can obtain  $x$ , as was follows.

with other nodes by wireless, exchanged control information and sent and received information data; energy supply unit was responsible to provide the operation of energy required for the entire nodes, the battery power supply usually was adopted, and its energy was limited.

According to the previous analysis, the processing unit and wireless transceiver unit were implemented redundancy configuration. According to state transfer principle of the sink node module, after nodes were initialized, the main module was in normal work state, and the spare module was responsible for

monitoring the work of the main module at the same time, in order to reduce the energy consumption of the spare module, we designed monitoring unit, and

replaced the spare module as monitoring the operation of the main module, the architecture of node was shown in Fig. 2.

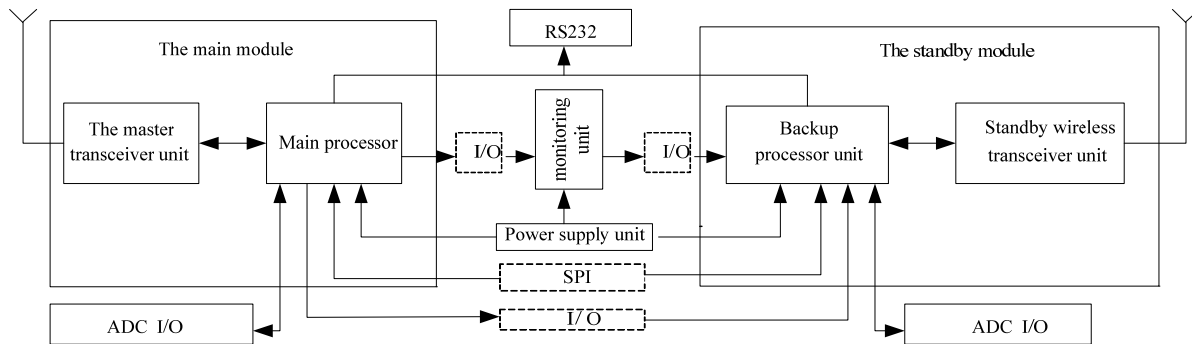

Fig. 2. The architecture of node.

Sink node that was designed in the paper mainly implemented data collection and transmission, and it composed of a master module, a spare module, monitoring unit and a power supply unit, the ADC interface and I/O were reservation. Master module composed of a main processor unit and wireless transceiver unit, and was work module that the sink node is in starting state; the monitoring unit monitored master module state by the I/O interface of master module, once the master module processor had hardware permanent fault, the monitoring unit can wake up the spare module through the I/O interrupt; the spare module structure consisted with master module, and also included a processor unit and wireless transceiver unit. Due to DSP TMS320F28335 have the characteristics of low power consumption, high reliability, strong processing ability, and it was taken as Main processor module, CC2420 was taken as radio frequency chip; Spare module microprocessor was the same as the main processor module, and CC2430 was taken as radio frequency chip. In general, in order to reduce the energy consumption of nodes, the main and spare modules were only one in working state, if the application of data reliability requirement was higher, the main and spare module can work at the same time and communicate by SPI interface, and sink node had the function of data reliability test; the power supply unit provided energy source for the entire node.

## 5.2. Sink Node Work Process Design

Wireless communication module was the main source of node energy consumption, the efficiency of energy saving had the influence on performance of the network, so TDMA time slot allocation was adopted in communication, the transmission collision was avoided by reasonable TDMA scheduling, and reduced the idle listening time of the nodes, periodically sent and received data, realized the

energy saving of the whole system. The data collection process in Network had the characteristics of periodic, and sink nodes in subnet periodically collected sensory information of all sensor nodes. According to the sink node architecture and the principle of state transition, the working process in sink node mainly consisted of the working process of main module, the working process of backup module and the working process of monitoring unit.

For main module, it was in a low power state when the node was initialized, namely, the CPU was in dormant state, wireless transceiver CC2420 was in the listening state, the CPU can be awakened by radio frequency interrupt and timer interrupt, respectively, perform data reception and a periodic task between subnets, and enter a dormant state after the task was smoothly completed, if the communication link failure occurred in the implementation process and it was still not solved by the retransmission, and the backup module was waken up by I/O interrupt. In order to solve the fault of main processor module, after initialization was over, the main module delivery status signal to the monitoring unit by I/O port.

For standby module, it was in a state of low power consumption after the node was initialized, but sleep mode and the awaken mechanism were different from main module, CPU and wireless transceiver were all closed, the CPU was waked up through the I/O interrupt by the monitoring unit or the main module processor. Once it was awakened, the standby module instead of the main module completed task of sink node, and stopped the work of monitoring unit.

For monitoring unit, the monitoring unit was in the work state after node was initialized, and it received the state signal from main module through the I/O port, once time that can't receive the state signal was much bigger than a predefined threshold T, monitoring unit waked up backup module through the I/O interrupt.

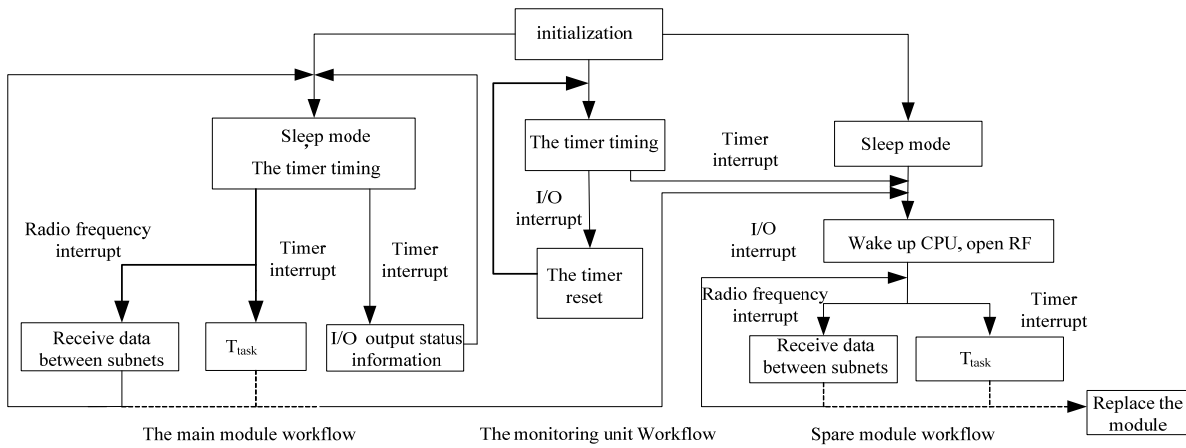

Fig. 3. The flowchart of sink node.

## 6. Experiment and Simulation

When the communication link quality in wireless sensor network was affected by the interference, obstacles, etc, and it would change at any time, when the link quality fallen to a certain degree, the phenomenon of packet loss occurred. while it was difficult to take measures to improve the quality of communication link, the retransmission mechanism in the data transmission and the use of the spare module can filter the poor link on certain level, and improve the reliability effect of the overall communication link, therefore this section verified the reliability of sink node by detecting reliability of the whole communication link.

At the moment, the link quality evaluation methods were widely used, and packet reception rate was calculated through statistical methods (packet reception rate, PRR) in methods, the packet reception rate can intuitively reflect the current link status, however, CC2420 and CC2430 chips have with more sensitive and efficient link communication quality measurement method. Receives information intensity (received signal strength indicator, RSSI) and link quality display (the link quality indicator, LQI) in chips can reflect the link quality of communication, due to evaluate accuracy RSSI was not high, and cannot serve as a good link quality measure indicators, so this article chosen LQI evaluation method that has been mostly used in the simulation study [6, 7].

Supposed that  $LQI_k$  was the k time communication link quality, and  $LQI_{avg}$  that was average value of N time LQI statistical value, was given in the following.

$$LQI_{avg} = \frac{1}{k} \sum_{k=1}^N LQI_k \quad (12)$$

In the paper, we researched LQI variation law and statistics mean of sink node that designed by oneself (MyNode) and general sink node (NormalNode), and the reliability test results were obtained. Two the

same performance sensor nodes were taken as senders, respectively, and sent data to MyNode and NormalNode at the same time. LQI value of sink node in each cycle was recorded, and calculated the LQI statistical average, the contrast experiment and the analysis of experimental results under the different environment were given in the following.

### 6.1. Obstacles Interference

The obstacles interference sources have many, in the paper, the simulated experiment was done in the case of interference that people walking around and metal equipment caused.

In the case of people walking around, according to experimental idea, the transmission power of sensor node was set to 0 dBm, the distance of nodes was set to 2 meters, sensor nodes 1 and 2 sent 80 groups of data to MyNode and NormalNode respectively, in 10th cycles and 47th cycles, the personnel moved frequently between sensor nodes and sink nodes, the experimental results were shown in Fig. 4 (data points step was 5). As can be seen from Fig. 4, the communication link quality was overall better in the laboratory, LQIavg of MyNode and NormalNode were greater than 100; People walking around had certain influence on the link quality, LQI values of two sink nodes were generally less than 100 during interference; MyNode adopted retransmission mechanism to avoid the link transient fault that people walking around occurred, the phenomenon of packet loss didn't happen, by contrast, NormalNode existed a packet loss (LQI value of 50), so LQIavg of MyNode was slightly higher than that of NormalNode.

In case of metal equipment, the transmission power of sensor node was set to 0 dBm, the distance of nodes was set to 2 meters, sensor nodes 1 and 2 send 80 groups of data to MyNode and NormalNode respectively, in 15th cycles and 55th cycles, the mental equipment was shaken between sensor nodes and sink nodes, the experimental results were shown in Fig. 5 (data points step is 5).

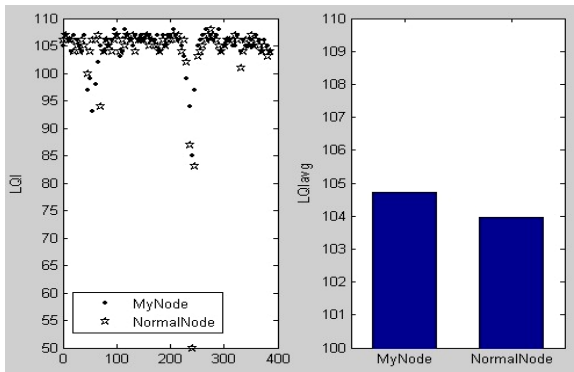

Fig. 4. LQI and LQIavg of MyNode and NormalNode in the case of people walking around.

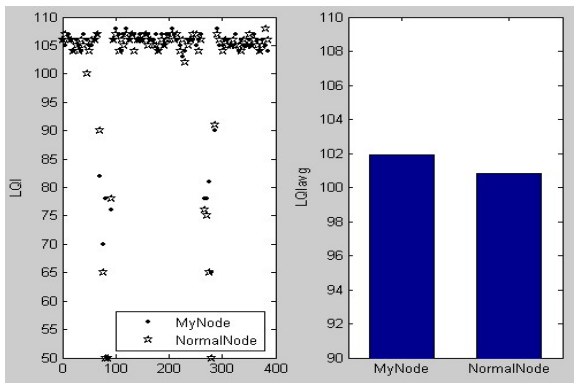

Fig. 5. LQI and LQIavg of MyNode and NormalNode in the case of mental equipment interference.

As can be seen from Fig. 4, compared with the results that people walking around come into being, metal equipment had influence on link quality, and it is much bigger, MyNode and NormalNode had all phenomenon of packet loss (PRR were 0.9875 and 0.975 respectively), and in the case of packet loss, the minimum value of LQI was 65; in the case of metal equipment interference, the range of LQI was 50~100, due to the retransmission mechanism and the use of the spare module, the success rate of data transmission was improved, compared with Fig. 4, the LQIavg of MyNode had slightly declined, but it was slightly higher than NormalNode.

## 6.2. Transmission Distance

Transmission distance of wireless sensor network is short, and it is one of the characteristics of WSN, if the distance between nodes deployment is much bigger, the link quality will decline, and packet loss is caused. However, transmission distance was not a linear relationship with packet loss rate, namely, there was an unstable region, the communication link quality in this area was not stable, packet loss would happen at any time [6]. In theory, if NormalNode and MyNode placed in the region, compared with NormalNode, the packet loss rate of MyNode was smaller, to some extent, the transmission distance of network can be improved.

Because laboratory space was limited, and there were the wall block and personnel moving interference and so on, the experiment was conducted in the open outdoor. the distance between sensor nodes and sink nodes was set to 1 meters, the sensors transmitted power was set to 0 dBm, sensor nodes 1 and 2 sent 5 groups of data to MyNode and NormalNode respectively, and gradually increased the distance (1 m) between the nodes, repeated the same experiment, the experiment results were shown in Fig. 6.

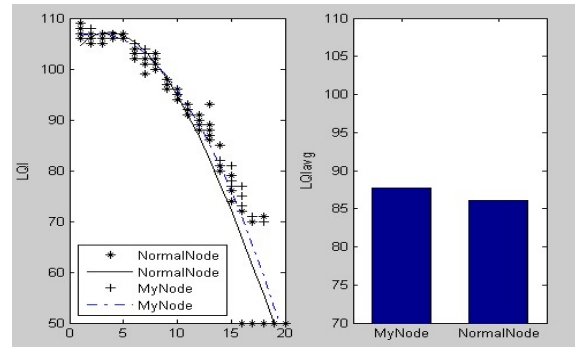

Fig. 6. LQI and LQIavg of MyNode and NormalNode in the case of different distance.

It can be seen from fitting curve in Fig. 6 that experimental results consisted with theoretical analysis, transmission distance of MyNode was slightly longer than NormalNode, and the overall communication link quality of MyNode was higher than that of NormalNode from the perspective of LQIavg.

## 6.3. Transmission Power

Due to the energy of nodes was supplied with battery power in wireless sensor network, and energy was seriously limited, in order to prolong the network lifetime, in generally, the low transmission power was adopted to reduce the network energy costs, however, if the transmission power was reduced, and the packet reception rate would decline. Transmitted power was linear relationship with the packet loss rate, and there was an unstable region too [6]. In theory, if MyNode and NormalNode were placed in the region and received data, compared with NormalNode, to some extent, MyNode can avoid packet loss, and improve the quality of the communication link.

The experiment was done in the laboratory. The distance between sensor nodes and sink nodes was set to 2 meters, and guaranteed that the data transmission was not affected by the transmission distance, the transmitted power of the sensor nodes 1 and 2 was set to 0 dBm, sensor nodes 1 and 2 send 5 sets of data to MyNode and NormalNode respectively, when the node transmission power was changed, the same experiment was repeated, the experimental results were shown in Fig. 7.

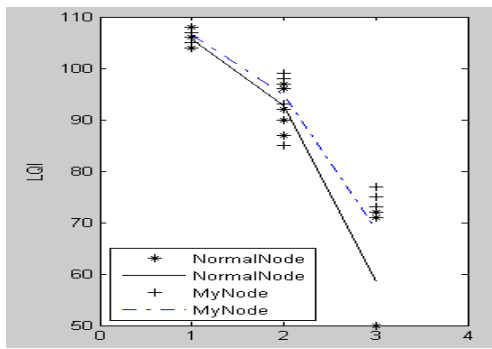

(a)

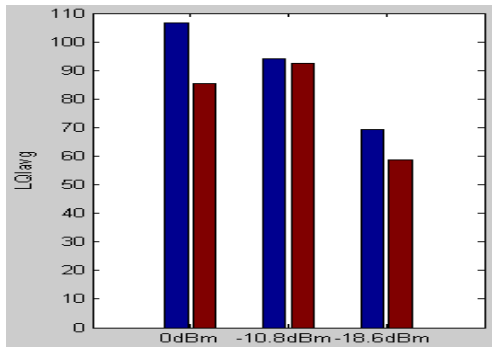

(b)

Fig. 7. LQI and LQIavg of MyNode and NormalNode in the case of different transmitted power.

In Fig. 7(a), 1, 2 and 3 on the horizontal axis expressed that the transmitted power was 0 dBm, 10.8 dBm and 18.6 dBm respectively, it can be seen from LQI fitting curve that LQI had overall a downward trend when the transmitted power reduced, but the MyNode LQI decline rate was lower than that of NormalNode. Fig. 7(b) shown that MyNode overall communication link quality was higher than that of NormalNode in the case of different transmission power.

In a word, three sets of reliability experiment results shown that MyNode can avoid the transient fault of the communication link in a certain extent compared with NormalNode, in the case of the communication distance was longer or under the condition of the transmission power was lower, MyNode had more packet reception rate than NormalNode.

## 7. Conclusions

It was an important problem that the reliability was much lower in the wireless sensor network

applications, in the paper, on the basis of improving network reliability at domestic and foreign, for sink node reliability, we discussed from reliability model, software and hardware design and the reliability test, etc. The experimental results shown that, compared with the general sink node, we designed the sink node that can avoid the transient fault of communication link in a certain extent, and has strong anti-interference ability; In the case of communication distance was longer or under the condition of the transmission power was lower, the packet reception rate was greater.

## Acknowledgment

This work was supported by the Priority Academic Program Development of Jiangsu Higher Education Institutions (PAPD) and Project BK2011398 of the Jiangsu Province Natural Science Foundation.

## References

- [1]. Xu Wenyua, Trappe Wade, Zhang Yanyong, Defending wireless sensor networks from radio interference through channel adaptation, *ACM Transactions on Sensor Networks*, Vol. 4, Issue 4, 2008, Article No. 18.
- [2]. Alam Muhammad Mahbub, Hong Choong Seon, CRRT: congestion-aware and rate-controlled reliable transport in wireless sensor network, *IEICE Transactions on Communications*, Vol. E92-B, No. 1, 2009, pp. 184-199.
- [3]. Mukhopadhyay Shoubhik, Schurgers Curt, Panigrahi De-bashis, et al., Model-based techniques for data reliability in wireless sensor networks, *IEEE Transactions on Mobile Computing*, Vol. 8, Issue 4, 2009, pp. 528-543.
- [4]. Hao Wen, Chuang Lin, Fengyuan Ren, et al., Retransmission or redundancy: transmission reliability in wireless sensor networks, in *Proceedings of the IEEE International Conference on Mobile Adhoc and Sensor Systems (MASS'2007)*, 8-11 October 2007, pp. 1-7.
- [5]. Xie Xiren, Network of computer, Electronic Industry Press, Beijing, 2003, pp. 75-77.
- [6]. Sun Peigang, Zhao Hai, Luo Dingding, Study on measurement of link communication quality in wireless sensor networks, *Journal on Communication*, Vol. 28, Issue 10, 2007, pp. 14-22.
- [7]. Zhang Xiyuan, Zhao Hai, Zhu Jian, Xu Jiuqiang, LQI based on link evaluation algorithm and its application in wireless sensor networks, *Journal of Northeastern University (Natural Science)*, Мщдю 29, Issue 12, 2008, pp. 1693-1696.