



The Wireless Notification System for the Hearing Impaired

Andrew Foo Thai Hin¹, Elmy Johana Mohamad²

¹Mechatronic and Robotics Engineering Department, Faculty of Electrical and Electronic Engineering, Kolej Universiti Teknologi Tun Hussien Onn, Malaysia,
E-mail: fu_daxin@yahoo.com

²Mechatronic and Robotics Engineering Department, Faculty of Electrical and Electronic Engineering, Kolej Universiti Teknologi Tun Hussien Onn, Malaysia,
E-mail: elmy@kuittho.edu.my

Received: 13 June 2006 Accepted: 19 July 2006 Published: 25 July 2006

Abstract: The Wrist Alert is intended for the use by the hearing impaired in their home environment. It alerts the user to signals such as smoke detectors and doorbells. These signals are connected to a centralized controller box, processed, and transmitted via a Radio Frequency link to the wireless wristband device. The alerting mechanism employs vibration, a discreet form of notification that helps minimize disruption to everyday life in the household. The Wrist Alert utilizes different vibration patterns to differentiate between designated priority levels and the associated signal sources.

Keywords: Hearing impaired, ALD (Assistive Listening Device), RF (Radio Frequency), transmitter, receiver, vibrator

1. Introduction

This project is to investigate vibration as a form a notification. The vibrator must vibrate strong enough to alert the user to each signal. The second is to study various interfacing circuit for PIC. This includes the fabrication of PCB layout for each sensors circuit and the relay control circuit. The third is to find out the method to achieve various vibration patterns. The vibrator must vibrate in two different patterns to differentiate signal received. Lastly, this project is limited to the investigation the performance of the wireless system. The wristband device will be tested in various distance from the controller box for home environment only.

This project is proposed because the problem faced by the hearing impaired as listed such as the hearing impaired cannot hear even wearing hearing aids for severe cases. Besides, family with hearing impaired members may be annoyed by the notification from various ALD. It emits loud noise that caused disruption in house. Flashing light device is also a kind of disruption especially at night. Moreover, existing ALD are very expensive and each are sole separately.

At the end of this project, the wristband device is expected to alert the hearing impaired to doorbell and smoke alarm. Moreover, the control box is expected to process and transmit the signals to the wristband and the wristband can vibrate in two different patterns.

Various hearing aids are available in the market such as Siemens' leading-edge digital technology ACURIS, advanced digital processing TRIANO and PRISMA 2, enhanced basic digital processing MUSIC Pro and INFINITI Pro and lastly the most basic PHOENIX and PHOENIX ONE. Other manufacturer's includes Bernafon, GN Resound, Miroctech, Oticon, Phonak, Rexton, Sonic Innovation, Starkey, Unitron and Widex. They are made to selectively increase the volume of the sounds to hear and make soft sounds audible, while at the same time making moderate or loud sounds comfortable. Hearing aids are designed to provide relief in both noisy and quiet situations.

Besides, there exist cochlear implants of increasing complexity and effectiveness. These are useful in treating the mild to profound hearing impaired. Various assistive listening devices (ALDs) that work with or without hearing aids are available to the hearing impaired. These include amplified telephones, alarm/alert devices, infrared listening systems and personal communication devices. Amplified telephones have the ability to increase sounds beyond normal phone volumes and heighten high frequencies, or pitches, that are important to understanding phone conversation. ALDs such as alarm clocks and fire alarms emit a very loud signal or alert the hearing impaired through other sensory cues such as flashing lights or bed shaking.

No hearing aid can solve every hearing problem or restore normal hearing, but they are designed to provide amplification so that the hearing impaired can hear and understand better. Hence there exist devices that implement vibration and flashing lights as a form of notification for the hearing impaired when hearing aids cannot solve the hearing problem. This includes pillow vibrator, Super shaker bed vibrator and doorbell signalers.

Pillow vibrator is a pillow with a build-in alarm clock in the pillow. It will vibrate when the user had set the time to wake up. Super Shaker bed vibrator is device that is place under the bed of the user and is attached to the alarm clock. It has two form of notification, which is vibration and flashing light. As for the doorbell signalers, its form of notification is by flashing the lights that is attached to the device.

2. Methodology

This project is divided into 2 parts, which is hardware and software. Referring to Figure 1, the main hardware is a controller box and a wristband device. The controller box consists of a microcontroller, 2 sensors and a transmitter. The 2 sensors used are push button and thermistor. The push button is used to sense the presence of doorbell signal while the thermistor is used to detect temperature changes. These sensors are connected to a PIC to be processed prior to be sent to the transmitter. Then, the transmitter transmits these processed signals to the wristband device. The wristband device consists of a receiver and a vibrator. The receiver converts these transmitted signals into voltage. These voltages are connected to the vibrator. Hence, vibration is developed. (Fig.1). The software part consists of MPLAB IDE and EAGLE. MPLAB IDE is used to program the PIC while EAGLE is used to create layout for PCB fabrication.

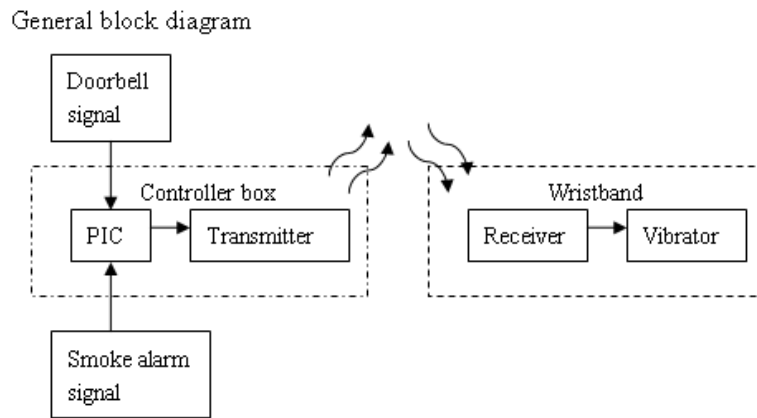

Fig. 1. General block diagram of the wireless notification system for the hearing impaired.

2.1 Doorbell Detection System

Doorbell signal is obtained by connecting a wire to the doorbell system. As shown in Figure 2, a normally opened (push to on) push button is arranged to form a pull-down resistor. One of the terminals of the push button is connected to +Vcc, which is +5V while the other is connected to the desired input pin of PIC. In this project, it is connected to PIC16F877A pin 5 of port B (RB2).

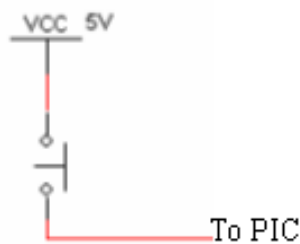

Fig. 2. Push button interfacing PIC.

2.2 Heat Detection System

A thermistor is used for smoke alarm system. Its electrical resistance changed when temperature changes. A negative temperature coefficient (NTC) thermistor is implemented into this prototype. As temperature increased, the resistance decreased. A comparator is implemented to compare the reference voltage V_{ref} and thermistor voltage, V_t . Any operational amplifier (op-amp) can be used to configure a comparator. In this project, a low power quad op-amp (LM324N) is implemented. Figure 3 shows the pin assignment for op-amp LM324N. The setup for heat detection circuit is shown in Fig. 4.

Pin 4 is connected to +Vcc, which is +5V while pin 11 to ground (gnd). The ground here refers to the negative terminal of the power supply. Connect the resistor $R1$ series with potentiometer $R2$. Besides, connect resistor $R3$ series with resistor $R4$. The thermistor denoted by R_t is connected parallel to $R4$. The interconnection between $R1$ and $R2$ is connected to pin 3 while the interconnection between $R3$ and $R4$ is connected to pin 2. The output pin, pin 1 is connected to PIC16F877A's input, which in this project is assigned to pin1 of portB (RB1).

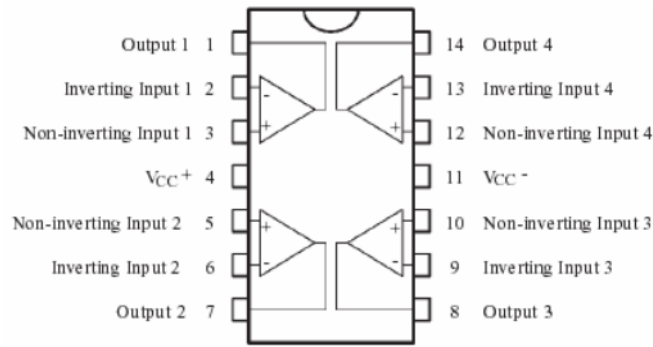

Fig. 3. Pin assignment for LM324N.

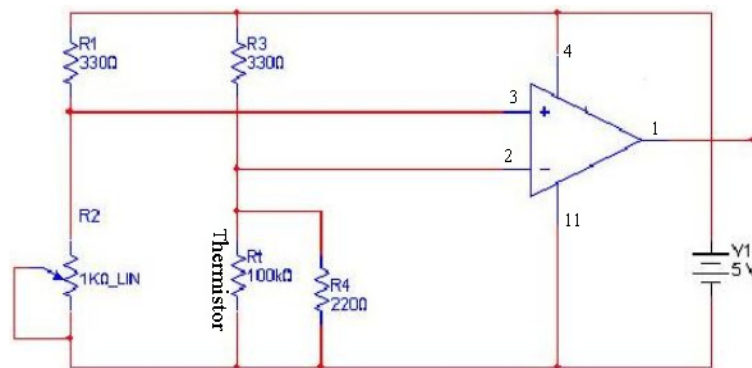

Fig. 4. Schematic of heat detection circuit.

2.3 Controller Box Processing Unit (Microcontroller Unit)

The microcontroller unit (MCU) used in this project is Microchip PIC (Peripheral Interface Controller) 16F877A. The program is written by using Microchip’s software, which is MPLAB IDE (Integrated Development Environment). The program is burned into the PIC by using PIC Start Plus, a hardware that is developed by Microchip. A flow chart must be determined prior to writing using MPLAB IDE. Below is the flowchart that serves the purpose of the project. Figure 5 shows the flowchart of this project.

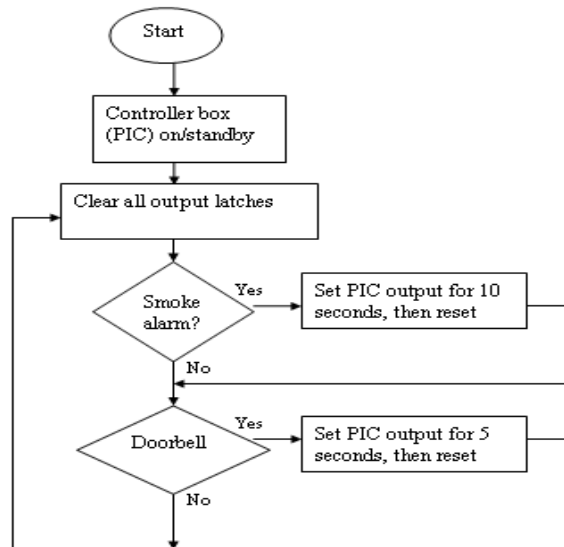

Fig. 5. Program flowchart for this project.

2.4 Switching Device

Transistor and relay are used as switch in this project. Figure 6 shows the configuration of a 2N3904 npn bi-polar junction (BJT) transistor and the JZC-6F mechanical relay controlled by PIC. The base (B) of the transistor is connected to the PIC. In this project, we use RB5 to control the transistor. The emitter (E) is connected to ground while the collector (C) is connected to one of the power supply terminal (PS1) of the relay. The other power supply terminal of relay (PS2) is connected to +6V power supply since JZC-6F needed +6V to operate. The normally open (NO) and common (c) terminals are connected to transmitter.

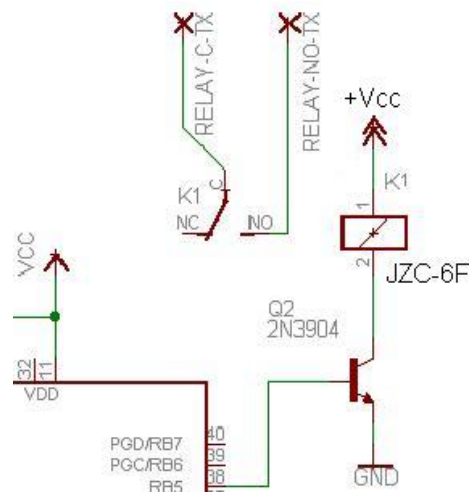

Fig. 6. The configuration of transistor and relay controlled by PIC.

2.5 Transmitter

The transmitter used in this project is obtained from a remote control (RC) car. The transmitter plastic casing is removed using screwdriver to obtain its circuit board. Two holes are drilled on the transmitter so that they can be connected to the common (c) and normally opened (NO) of relay. Wires are soldered on both the holes and the common and normally opened so that they are electrically connected.

On the other hand, the transmission distance test is determined from the number of tiles between the transmitter and receiver. This test is run in a house which has tile with the dimension of 33 x 33 cm. Light of sight (LOS) transmission is run in with no obstacles along the transmission path towards the receiver. Moreover, the not LOS test is run with the receiver place into a room with its door closed. Count the number of tiles until no transmission can be received to determine its maximum range for both LOS and none LOS transmission. The distance is calculated as the product of number of tiles times 0.33 meter.

2.6 Receiver and Vibrator

The receiver is obtained from the remote control (RC) car while the vibrator is obtained from an old model hand phone. Both the plastic casing of remote control car and hand phone are removed by using suitable tools such as screwdriver and Allen key. The output of receiver circuit is connected to the vibrator.

Experiments are run to find out the relationship between the receiver input voltage and receiver output voltage. The transmitter is made sure of transmitting signal as this experiment start. The receiver input is connected to the DC power supply with 3V and the receiver output voltage is measured by using multimeter. The measured value is written in a table. The test continues by incrementing the input voltage by 1 V. This experiment is run until 9V since further increment will burned the receiver circuit. The vibrator is placed at receiver output. The degree of vibration is observed as the DC power supply to the receiver input is incremented from 3 V until 9 V.

3. Result

3.1 Heat Detection System

Table 1. Resistance measurement.

Component	Value (Ω)	Measured Value (Ω)
Resistor, R1	220	190
Potentiometer, R2	1K	130
Resistor, R3	330	320
Resistor, R4	220	220
Thermistor, R_t	100K	60K (room temperature)

Since R_4 and R_t are parallel, the effective resistance, R_{4t} is calculated as below:

$$R_{4t} = \frac{R_4 \times R_t}{R_4 + R_t} = \frac{220 \times 60k}{220 + 60k} = 219.2k\Omega \quad (1)$$

By using voltage divider rule, the voltage into the inverting input V_t is calculated as below.

$$V_t = \frac{R_{4t}}{R_3 + R_{4t}} \times V_{cc} = \frac{219.2}{320 + 219.2} \times 5 = 2.03V \quad (2)$$

The same rule applies to the none-inverting input of op-amp.

$$V_+ = \frac{R_2}{R_1 + R_2} \times V_{cc} = \frac{130}{190 + 130} \times 5 = 2.03V \quad (3)$$

Table 2. Op-amp output voltage.

Condition	Output at Pin 1
Room temperature	0 V
Thermistor heated	5 V

Initially, the potentiometer is calibrated so that the voltage output is equal to 0 V. The thermistor used in this setup is negative temperature coefficient (NTC). Its resistance will decrease as the temperature rises and vice versa.

When the thermistor is heated, the temperature rises and the thermistor's resistance R_t is decreased. According to equation (1), as R_t decreased, the effective resistance R_{4t} also decreased. Hence,

according to equation (2), the voltage V_t to the inverting input also decrease. The voltage to the non-inverting input V_+ is still remained at its original state. Hence, when compared, voltage V_+ wins and the output change from 0 V to 5 V.

According to equation (2) and (3), both the voltage input to the comparator is the same. So calibration of potentiometer, R_2 is needed to adjust the best sensitivity for the thermistor at different room temperature. The resistance of the potentiometer, R_2 must be decreased if the output of the op-amp before the heating of the thermistor is high.

3.2 Doorbell Detection System

Table 3. PIC input voltage from doorbell.

Condition	PIC input voltage (V)
Not pushed	0
Pushed	5

At pushed, the connection is made and PIC will detect the change from low to high state. If the button is not pushed, the PIC will remain still until the button is pressed.

3.3 Controller box processing unit (Microcontroller Unit)

Table 4. PIC's responses to sensors.

Detection	Heat		Doorbell	
	Yes	No	Yes	No
RB5 (V)	5	0	5	0
Transistor on time (s)	10	Off	5	Off
Relay	NO	NC	NO	NC
Transmitter	On	Off	On	Off

As long as either heat or doorbell is detected, PIC output pin RB5 changed from 0 to 5 V. The transistor on time is purposely programmed differently so that for heat detection, it has longer transmission time. If RB5 high, transistor is on, then relay change from NO to NC. Transistor is activated if the relay is at NC.

3.4 Transmitter performance

The transmitter is able transmit signal up to 7.26 m. The vibrator is able to vibrate upon receiving signals from the transmitter for both LOS and not LOS transmission. The receiver will not response to any signal further than 7.26 m.

3.5 Receiver and Vibrator

As long as the receiver circuit is supplied by a minimum voltage of 3 V, the receiver is able to received signal from transmitter and output its voltage to the vibrator to vibrate.

However, when the DC power supply is replaced with a source of battery measured as 3 V, the vibrator does not vibrate. This is due to the fact that voltage supplied by battery is not constant and will drop according to time. From the experiment, the discovery made is that the higher the voltage, the greater the vibration. This is due to the fact that output at the receiver is directly proportional to the input voltage supplied. Since size of the battery is a constrain (the user would not want to wear a heavy wristband), the best alternative is to use A23 battery which is smaller in size. An experiment had been run to test the sustainability of the receiver circuit to withstand 12 V power supply. It is run over and over again to test it durability. The result shows that the degree of vibration decreased with the drop of the potential difference of the battery. The drop in the degree of vibration will result in a drop in the sensitivity of the wristband user.

Hence, for reasons of durability and sensitivity, and constrains of sustainability and size, the receiver circuit output (vibrator) do not need conditioning circuit.

6. Conclusions

As a conclusion, the notification for the hearing impaired by implementing Wristband Alert system is a splendid choice because vibration as a form of alerting mechanism helps minimize disruption to everyday life in household. The wristband acts as a life-saving tool to notify the hearing impaired during outbreak of fire in the house. Beside doorbell and smoke alarm signals, additional sensors can be added to upgrade the function of the existing controller box without adding additional hardware to existing Wristband device. Wireless transmission also eliminates the need for wires and thus making life comfortable.

Moreover, the wristband device is cheaper than existing ALD. The ALD in the markets are very expensive and cost more than hundred Ringgit for one device. Each device serves only one function. The wristband device is built with all-in-one feature and at a price affordable to all. Moreover, the wristband device is reliable because it is accurate in processing signals. The doorbell detecting circuit does not triggered by sound and hence avoiding any false triggering.

However, this Wristband device is not waterproof. Hence, the hearing impaired will not be notified to signals when they took off the wristband device for water activities such as bathing and swimming.

Moreover, the wristband device may likely face interference due to its wireless (Radio Frequency) properties. Hence, the wristband device may vibrate even no signal was sent from controller box if there exist radio wave operating in the same frequency in the vicinity of the hearing impaired house.

References

- [1] Berlin, H. M. (1989). "Design of OP-AMP Circuits With Experiment." First Edition. Indianapolis, U.S.A. Howard W. Sams & Co. 54, 60, 110.
- [2] Bolton, W. (2000). "Microprocessor Systems." Singapore (KKP).: Pearson Education Asia Pte Ltd. 212-216, 263-264, 266, 293-295, 311.
- [3] Morton, J. (2001). "PIC Your Personal Introductory Course." 2nd. ed. Great Britain: Newsnes. 171-174.
- [4] Internet (2005). "A hearing aid" <http://www.ahearingaid.com/comparison.htm>

- [5] Internet (2006). "CadSoft Online/ EAGLE Users/ Download"
http://www.cadsoft.de/cgi-bin/download.pl?page=/home/cadsoft/html_public/download.htm.en&dir=eagle/program/4.1
- [6] Internet (2005). "Doorbell signalers"
http://www.allegromedical.com/daily_living_aids/hearing_aids/sonic_alert/doorbell_signalers.P189868
- [7] Internet (2005). "Hearing Aid Comparison Chart". <http://www.ahearingaid.com/comparison.htm>
- [8] Internet (2005). "Hearing Impairment". http://en.wikipedia.org/wiki/Hearing_impairment
- [9] Internet (2005). "How Hearing Aids Help".
http://www.siemens-hearing.com/consumer/hearing_Info/about_hearing_aids/how_hearing_aids_help.aspx
- [10] Internet (2005). "Other Devices That Help".
http://www.siemens-hearing.com/consumer/hearing_Info/about_hearing_aids/other_devices.aspx
- [11] Internet (2005). "Pillow vibrator"
http://www.allegromedical.com/daily_living_aids/hearing_aids/compu_tty/pillow_vibrator.P214818
- [12] Internet (2005). "Products/Hearing Instrument".
<http://www.siemens-hearing.com/professional/products/hearingInstruments/index.aspx>
- [13] Internet (2005). "Sonic Boom Alarm Clock":
http://www.allegromedical.com/daily_living_aids/hearing_aids/sonic_alert/sonic_boom_alarm_clock.P189872
-