

TORQSENSE™

OEM Rotary Torque Transducers For:

- *Condition Monitoring*
- *Motor & Machinery Control*
- *Automotive • Aerospace*
- *Viscosity & Consistency Measurement*

SENSOR TECHNOLOGY LTD of Banbury, announce a new radical technology for measuring rotary Torque.

Developed under a DTI Link programme, **TORQSENSE™** Transducers are the world's first low cost non-contact rotary torque transducers designed for OEM applications.

Rotary torque has always been difficult and expensive to measure, but, by using existing technology in a novel way, inexpensive transducers can be produced for situations where monitoring or control of drive mechanisms is required.

The patented method uses a surface acoustic wave device used as a frequency dependent strain gauge and measures the change in resonant frequency caused by the applied strain in the shaft. The signal is transmitted via an RF couple from the rotating shaft to a fixed pick-up. By using a frequency based device, the signal bandwidth is increased, and the problem of electronic interference common with analogue signals is eliminated.

The **TORQSENSE™** transducers are designed to operate direct from a PLC or a PC, removing the need for conventional instrumentation, and will interface with standard DPM's. They require minimum length of shaft, have low inertia, no physical contact between shaft and housing, wide bandwidth, high resolution and accuracy, and excellent noise immunity. The technology lends itself to design of OEM transducers for specific customer applications.

Applications for the technology include automotive, manufacturing machines, and condition monitoring where knowledge of torque is critical to the performance of the systems, torque control of tightening procedures, as well as monitoring of torque during mixing processes where mix consistency is required.

In viscosity or extrusion applications the transducer is mounted inline with the drive shaft, and measures the drive torque required to operate the mixer or extruder. This enables measurements to be made of the relative viscosity or consistency of either small scale laboratory mixes or full scale production quantities, for example in process control situations where ingredients are added to the mix until a desired viscosity is achieved. Monitoring of slurry, chocolate and cement mixers and extrusion machines are among current applications.

Instrumentation versions will feature enhanced accuracy and resolution to better than one part in a million, and it is envisaged that the technology will replace existing types of rotary torque transducers by providing better performance at a lower price.

Press Release Version 2AC

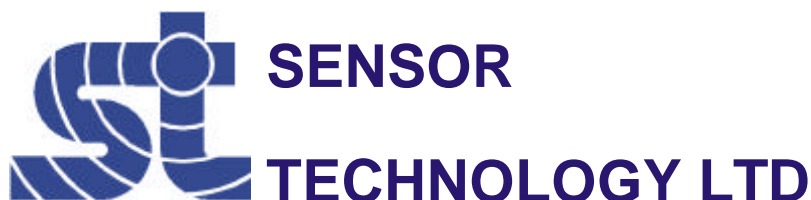

PO Box 36, Banbury,
Oxon, England OX15 6JB

Phone/Fax: +44 (0) 1295 730746

Email: info@sensors.co.uk

Web: <http://www.sensors.co.uk/c14.html>

TORQSENSE™

High Bandwidth

High Resolution

Contactless

Small Size

Accurate

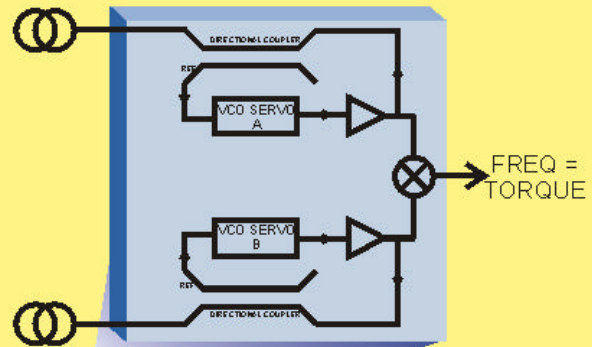

Electronic interface

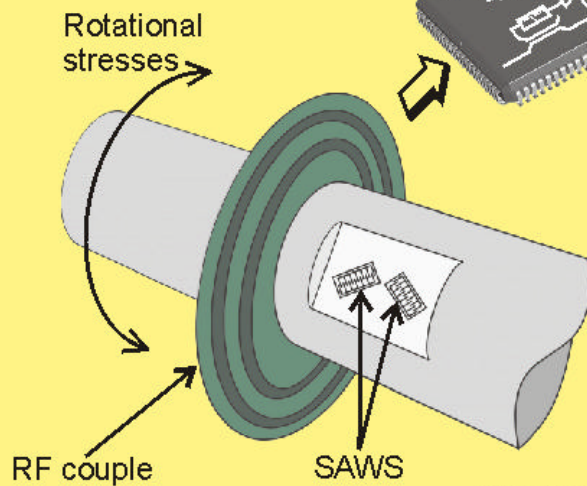

Sensitive

Low Cost

High Reliability

Suitable for OEM applications

 **SENSOR
TECHNOLOGY LTD**

PO Box 36, Banbury,
Oxon, England OX15 6JB

Phone/Fax: +44 (0) 1295 730746

Email: info@sensors.co.uk

Web: <http://www.sensors.co.uk/c14.html>

TORQSENSE™



A 200 Nm TORQSENSE RWT Transducer

 **SENSOR
TECHNOLOGY LTD**

PO Box 36, Banbury,
Oxon, England OX15 6JB

Phone/Fax: +44 (0) 1295 730746
Email: info@sensors.co.uk
Web: <http://www.sensors.co.uk/c14.html>