

## Design and Implementation of an Intelligent Expansion Module for Wireless Gas Sensor Networks

Grigore STAMATESCU, Iulia STAMATESCU, Dan POPESCU  
and Valentin SGÂRCIU

Department of Automatic Control and Industrial Informatics, University "Politehnica" of Bucharest,  
313 Splaiul Independenței, 060042 Bucharest, Romania  
E-mail: [grigore.stamatescu@upb.ro](mailto:grigore.stamatescu@upb.ro)

*Received: 9 February 2015 / Accepted: 27 March 2015 / Published: 30 April 2015*

---

**Abstract:** Wireless gas sensor networks (WGSN) offer the potential of high spatial and temporal resolution monitoring of target areas in both critical and non-critical scenarios. We describe the design and evaluation of an electronic expansion module, MICARES, suitable for gas sensing applications with wireless sensor networks. The module is intended for use with the MICA family of motes through the 51-pin connector. Proper housing assured, the device is applicable to both indoor and outdoor gas sensing for buildings, commercial and industrial spaces. Challenges lay in sensor selection, analytical and experimental power budgeting and field testing. We present the design goals at the network and node level and the adopted solutions to achieve them. Appropriate adaptive sampling strategies for energy efficiency, along with data resulting from CO<sub>2</sub> monitoring are described. Emphasis is put on embedded sensor integration into the electrical design and methods for on-board data acquisition and processing for decision support at the node and network levels. *Copyright* © 2015 IFSA Publishing, S. L.

**Keywords:** Gas sensors, Expansion module, Wireless sensor networks, Embedded sensing, Data processing, MICARES.

---

### 1. Introduction

Embedded networked sensing represents a very active field of research with input coming from different areas in electrical engineering and computer science. The idea that some phenomena can be closely monitored and acted upon with the help of miniaturized computation and communication devices has been well adopted by the research community and has spawned new directions in hardware and software design, communication protocols, measurement and actuation strategies or data management. Due to the low cost of the devices and autonomous operation, high density deployments are currently in use in military applications,

environmental studies, energy and transportation systems and healthcare.

Wireless sensor networks (WSN) are a particular class of embedded networked systems which offers specific advantages for indoor monitoring [1]. Apart from more conventional parameters, like temperature, humidity and light, more specialized sensors can be integrated into sensor nodes or motes. By measuring carbon dioxide, oxygen, ozone, carbon monoxide, volatile organic compounds (VOCs), methane, an new application direction is opened up. Having an overview in the form of an air quality map of the indoor conditions, the building operator and users can act in order to improve air quality and thus productivity and quality of life, and more important to avoid the risk of intoxication or explosion.

Leveraging the lack of wires, motes can be flexibly placed in the desired locations. The density of the deployment in terms of nodes per surface or volume unit can be adapted to the needs of the end user. Especially in the refurbishment of existing buildings there is a strong economic case to be made because of the lack of wiring which helps lower the deployment and maintenance costs associated with this installations.

Overall contributions of this work lay in:

- A modular wireless gas sensor network architecture enabling dense measurement of contaminants and communication via low power wireless protocols;
- Design, implementation and evaluation of an expansion board for indoor gas monitoring of carbon monoxide, ozone and carbon dioxide, which is relevant to the scientific community due to the widespread adoption of the MICA family of motes in sensor networks research;
- Considerations regarding adaptive duty cycling strategies for energy intensive sensors, along with an implementation of a periodic mechanism for gas sensor sampling.

The rest of the paper is structured as follows. Section 2 presents related work on similar developments for wireless sensor networks in gas monitoring scenarios where issues such as energy efficiency, adaptive sampling strategies and calibration are tackled. This frames our work into context and highlights the novel aspects of the contribution. Section 3 presents the system architecture for a wireless gas sensor network with modular sensing nodes and discusses sensor selection. We overview the main characteristics of electrochemical gas sensors and argument our choices. Section 4 consists of the design goals for the MICARES module, a versatile expansion module for the MICA family of motes and the implementation results. We overview the first revision, its integration with ubiquitous sensor networking platforms and testing results in CO<sub>2</sub> monitoring. Section 5 concludes the paper and paves the way for future work.

The current paper is a revised and extended version of the work originally published in [2] with added implementation details and methods for event detection for wireless gas sensing.

## **2. Related Work**

Gas sensing systems and networks are integrated into various process measurement devices, with emphasis on advanced data processing and calibration [3]. Regarding gas sensor integration into distributed embedded platforms, an overview of duty cycling strategies is shown in [4]. The surveyed strategies are applicable to a vast range of scenarios where energy hungry sensors have to be connected to constrained embedded devices. An implementation of

such strategies is in [5] where systems are built to wirelessly detect concentration of interest gases. The main contribution of the proposed system is to demonstrate the benefits in energy reduction obtained through context-aware adaptive duty cycling. A system capable of alerting in the case of high concentrations of combustible gas is described in [6]. Here the term of a wireless gas sensor network (WGSN) is coined. Contributions include the use of a pulse heating profile to achieve energy savings at the node level and the interconnection with GSM/GPRS and Ethernet networks for reliable alerts.

Operating low-cost gas sensors introduces the additional issue of periodic calibration and temperature and humidity effects compensation. As part of the OpenSense project [7] three calibration algorithms: forward calibration, backward calibration and instant calibration, are proposed. Reference calibration values can be obtained either in the laboratory, with a dedicated experimental set-up and artificial gas mixtures or by placing the systems in vicinity of high-precision, air pollution monitoring stations. Some commercial products have recently been proposed as expansion modules for WSNs, like the Libelium gases board for the Waspote platform [8]. Our work differentiates from this as it targets an open platform and, at the same time, provides the flexibility for stand alone operation or interconnection to different measurement systems.

## **3. System Architecture and Sensor Selection**

The proposed system architecture for wireless gas sensing is shown in Fig. 1. The wireless sensor nodes have a modular structure, composed of a main radio and processing board (MB) along with an expansion module (EM), tied through an interface connector. In our case, the gas sensing module is connected to the Memsic IRIS XM2110 board [9] and monitors an interest area for specific gas contaminants. This can be either a residential environment or an office or industrial building. A large number of such devices form a network of embedded devices, with low-power wireless communication in unlicensed Industrial, Scientific and Medical (ISM) bands, such as the 2.4 GHz band. Data is transmitted via multi-hop routes, where each network node also acts as a router, having the capacity to transmit its own data, as well as packets originating from neighboring nodes. A reduction of the necessary energy for radio transmission as well as an extension of the coverage area of the network is therefore achieved. Data is finally relayed to the radio base station and PC gateway, which stores it in a database for presentation, analysis and alerting. In our deployment, we use the XMesh protocol [10] for the reliable routing of data over the IEEE 802.15.4 standard lower levels for low-power wireless communication: PHY and MAC.

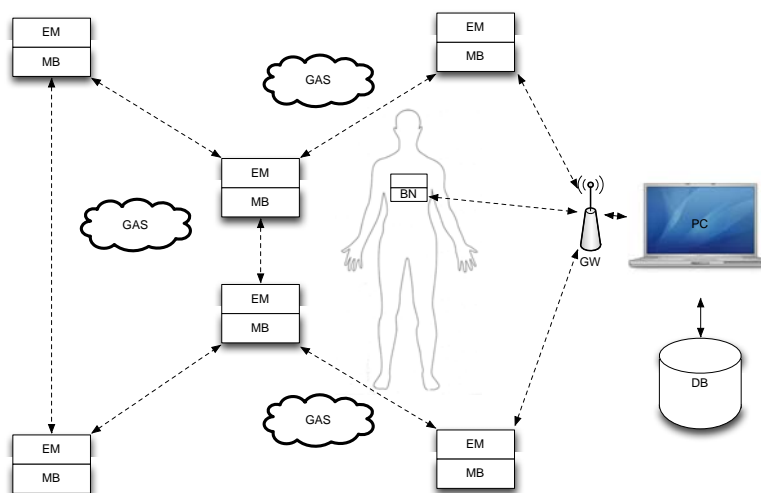

**Fig. 1.** Wireless Gas Sensor Network (WGSN).

The network can also be enhanced with dedicated body sensor nodes (BN) which can correlate in situ the effects of higher concentrations of specific gases in ambient air on the human body. Biometric measurements which can be assessed include: electrocardiogram (ECG), electroencephalogram (EEG), electromyogram (EMG), galvanic skin response (GSR), pulse oximetry, motion recognition.

One of the most important design choices when building such systems is the selection of the appropriate sensors for integration with the wireless node. We focus on measuring three gas concentration parameters: carbon dioxide, ozone and carbon monoxide. We found these three to be most relevant for our main indoor monitoring set-up. High concentrations of carbon dioxide diminish cerebral activity and can become dangerous in high concentrations. Ozone acts as an irritant to the respiratory system. Carbon monoxide, resulting from incomplete burning of organic materials, is a very toxic (deadly) gas.

The principle of operation of such devices is that the absorption or desorption of a gas on the surface of a metal oxide alters the conductivity of the material. The generic relationship governing the operation of semiconductor gas sensors is:

$$R_{sensor} = A \cdot C^{-\alpha}, \quad (1)$$

where  $R_{sensor}$  is the resistance of the sensor,  $C$  is the concentration of the target gas,  $\alpha$  is the slope of the  $R_{sensor}$  curve and  $A$  is the constant.

The metal layer has to be first heated to a given temperature and after that an output voltage is read proportional to the change in resistance in relation to the interest gas concentration. The voltage output of the sensor can be expressed as follows:

$$V_{out} = \frac{R_{ref}}{R_{sensor} + R_{ref}} \cdot V_{in}, \quad (2)$$

where  $V_{in}$  is the supply voltage,  $R_{ref}$  is the reference resistance and  $R_{sensor}$  is the resistance of the sensitive element, which varies with the detected gas concentration upon reaching the operating temperature.

The advantages stem from the simple construction, compact size and easy interfacing with data acquisition hardware. Drawbacks include variability among similar sensors due to manufacturing inconsistencies, low selectivity i.e. the output of the sensors is influenced not only by the target gas but also by other gases, usually given in the datasheet in the form of selectivity curves and, especially important for WSN applications, high current draw in the range of 40-200 mA for the heating phase (the average radio transceiver draws around 20 mA in operating mode). Some semiconductor gas sensors require cycling in order to clear the absorbant layer before a new measurement. By selecting an appropriate value for the reference resistor, the voltage output range of the sensor can be scaled to the input range of the ADC, in our case 0-2.5 V for the Atmel AT1281 microcontroller of the IRIS board. Essential characteristics of the selected sensors, manufactured by Hanwei Corp., are shown in Table 1.

**Table 1.** Electrochemical Gas Sensor Characteristics.

Type	CO <sub>2</sub>	O <sub>3</sub>	CO
Model	MG-811	MQ-131	MQ-7
Concentration (ppm)	350 - 10 <sup>4</sup>	10 <sup>-2</sup> -2	20-10 <sup>3</sup>
Voltage (V)	6	5 - 6	5
Current (mA)	200	190	70
Cross Selectivity	CO	CL <sub>2</sub>	H <sub>2</sub>

#### 4. Expansion Module Design and Evaluation

The designed electronic module consists of a printed circuit board hosting an Analog Devices ADUC832 chip. It is defined by the manufacturer as a smart transducer front end, including a 8-bit MCU along with high performance self-calibrating multichannel 12-bit ADC, dual 12-bit DACs, in a single package. The double 51-pin connector, type HiRose DF9B-51P/S is placed in the bottom part of the module. There are specific blocks for: external power supply, serial communication and signal conditioning. The serial interface is mainly used for programming the embedded microcontroller but it can also serve as support for serial MODBUS

communication. The sensors are placed in the right side of the device and we use sockets to house them as this allows for easy replacement and testing. The reference resistors for the sensors are variable, which allows the user to set the output range of the devices. The module is powered either from an external 5 V power supply or it can rely on the node's own supply by setting a jumper connector. Figs. 2(a) and 2(b) illustrate the block diagram along with the actual module. Also, Fig. 3 showcases, at the electrical diagram level, the integration of the MQ-7 carbon monoxide sensor into the module, and data acquisition for the smart transducer front-end analog input. A similar approach is taken for the other two sensors on the board as well.

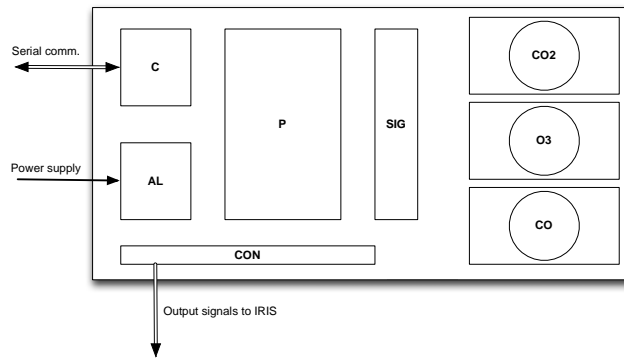

(a)



(b)

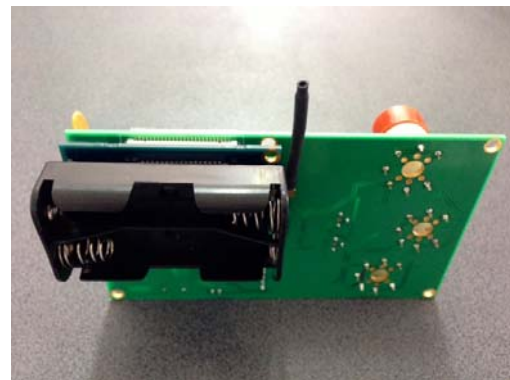

(c)

Fig. 2. MICARES WGSN Expansion Module (a) Block Diagram (b) Implementation (c) Side view, module attached to the node.

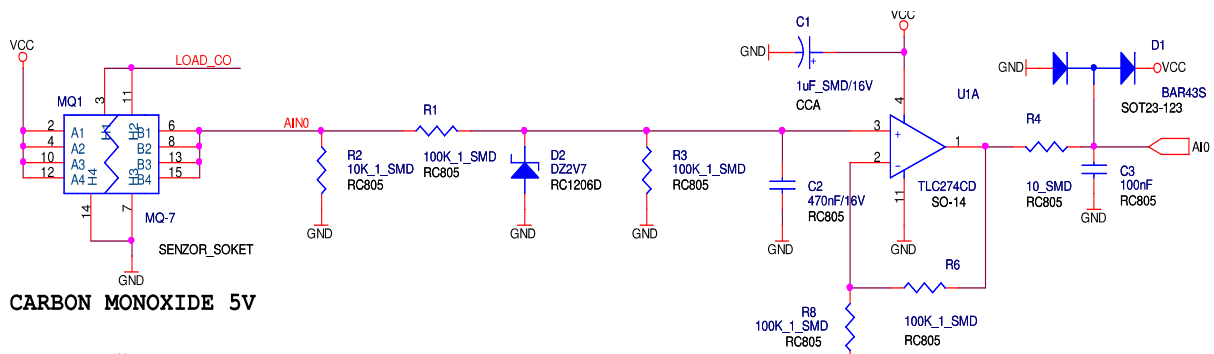

Fig. 3. Circuit Diagram for CO Sensor Integration.

The main design trade-off is increased complexity against versatility. By adding a microcontroller to the expansion board, the electric circuit becomes more complex, but we gain the possibility of using the device also as a stand-alone measurement system with serial communication. We are also able to implement the energy-reduction adaptive sensing strategies locally, on the module. Microcontroller power consumption is not a deciding factor as it is an order of magnitude lower than each one of the sensors.

Fig. 4 shows an example of collected data from the CO<sub>2</sub> sensor through ADC1 channel of the IRIS node. In this case we have operated the sensor continuously for 10 minutes, transmitting data packets from the node at 2 second intervals. High concentration events were simulated by breathing directly on the sensor in order to obtain an accelerated evaluation of the dynamic response. The sensor responds very fast to sudden changes in gas concentration which is suitable to our application where we aim at keeping it powered as little as possible. The readjustment to the normal values after the contaminant decreases is slower and there is a certain offset in the static behaviour. This leads to the conclusion that the system is well suited for alerting and alarming applications, while for precision applications, thorough and periodic calibration procedures have to be carried out.

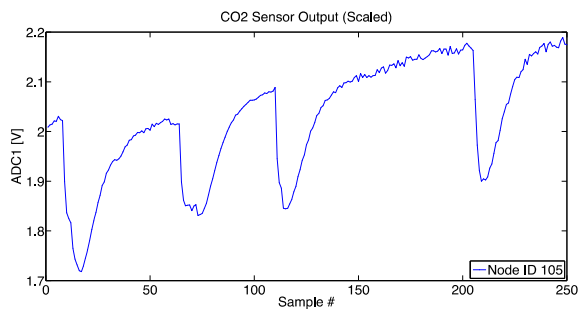

Fig. 4. Carbon Dioxide Sensor Output.

By means of raw data analysis, event detection and decision can be implemented directly on the wireless sensor node or at the node cluster level. The method is based on computing the filtered derivative of the measured signal. This tracks the dynamic of the measured process and a moving average filter is used for smoothing the resulting data set. Comparing the actual values with a pre-defined static or dynamic threshold level results in an action by the sensor node. The approach is applicable to both non-critical monitoring of carbon dioxide where the action can result in activating a digital output to start a fan for fresh air ventilation or critical tasks upon detection of high concentrations of carbon monoxide, resulting in general evacuation of the building. Fig. 5 illustrates the processed data and thresholding approach. In this case, we notice four high concentration events which

signal the need for local ventilation and alerting the facility manager. A two-stage decision framework can be further developed by including both and alert – yellow, and alarm - red levels. In such a way more fine-grained actions can be taken reducing the impact on the end user and mitigating false, positive and negative, alarms.

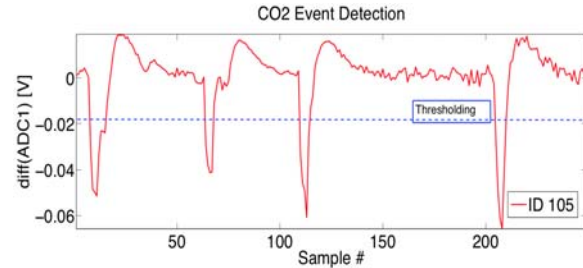

Fig. 5. Event Detection based on Acquired Data.

Acquired data is managed with the MoteView software tool [11]. It runs on the gateway PC and listens to the incoming serial packets from the radio base station. The packets are parsed and stored into a local database. The client visualization functionality displays the data in both numeric and graphical format.

Current software implementation assures the periodic operation of each of the sensors. Data is collected by the microcontroller which the outputs the values via the two built-in analog outputs. The IRIS module reads them through 10-bit ADCs 1 and 2 and embeds them into wireless low-power protocol packets. The embedded software, periodically activates the sensors according to the following algorithm and the graphical representation in Fig. 6:

- Power ON CO sensor, time constant TA POWER CO=30 seconds, 5 V power supply;
- Measurement cycle CO with TA CYCLE CO=100 seconds, 1.4 V power supply, at the end of the cycle updates AO 0 (to IRIS) with AI 0;
- Power ON O3 sensor, time constant TA POWER O3=30 seconds, 6 V power supply;
- Power ON CO2 sensor;
- Pause cycle between measurements, time constant TA PAUSE=200 seconds.

The CO sensor requires duty-cycled operation which consists first of a high power mode with heating voltage set at 5 V for at least 30 seconds (full power), which has the role of cleaning the sensitive layer of residual matter. Afterwards, the heater voltage is reduced at 1.4V (low power) for 100 seconds which enables reading the correct output value. During the pause cycle, the on-board 6 V power supply as well as the three sensors are powered off in order to save energy.

The parameters listed above can be used as knobs to fine tune the energy consumption of the node based on the application requirements. In the case of



slowly varying gas concentration the sampling rate is low, an increase triggers an alert level where the node performs dense measurements. The highest alarm level assumes continuous measurement and reporting. Once the dangerous situation is averted and the measurements return to a normal range, the sampling rate is reduced. One example is the adaptive sampling algorithm [12], implemented to achieve a reduction of measurement frequency to reduce energy consumption. Simple thresholding and moving averages can be computed locally on the node, while more complex operations, which require additional hardware resources, have to be handled at the network or network coordinator level.

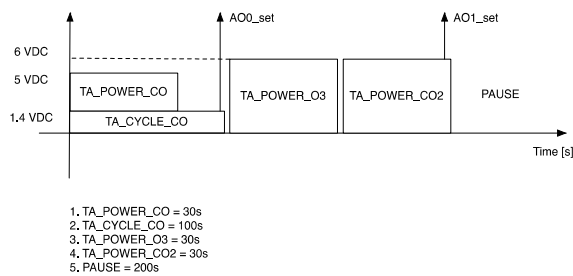

Fig. 6. Periodic Sampling of the Gas Sensors.

In addition, as sensor output changes with temperature and humidity we are also able to plot the correlation between these parameters in Figs. 7(a) and 7(b) respectively.

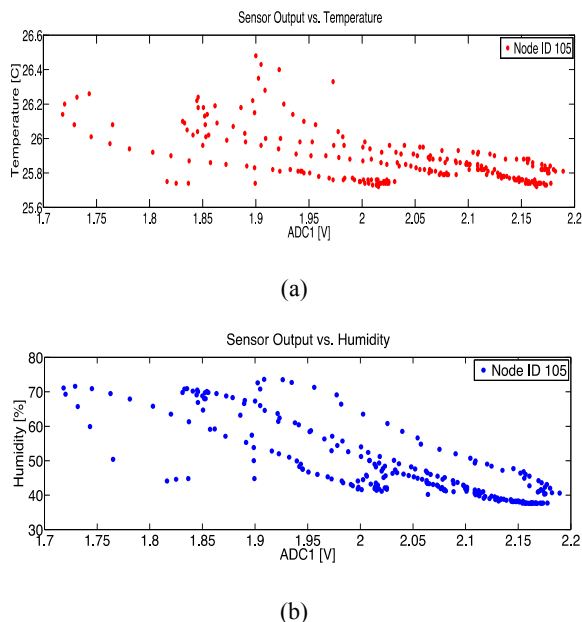

Fig. 7. CO<sub>2</sub> Sensor Output vs. Ambient (a) Temperature (b) Humidity.

According to the datasheets, sensor output is directly proportional with temperature and inverse proportional to the relative humidity. The variations

in ambient conditions have to be taken into account and the gas sensor output has to be compensated accordingly through locally implemented software routines.

As mentioned before, the collected data is packaged and routed via the wireless radio link. We use the XMesh routing protocol implemented in TinyOS which provides a higher level networking layer on top of physical (PHY) and medium access control layers (MAC, part of the data link layer), defined by the IEEE 802.15.4 standard for low-rate wireless personal area networks. It provides true mesh networking and reliable communication mechanisms. The specific packet structure is based on a generic miniature data acquisition module, the Crossbow MDA300 board, adjusted to accommodate the specific structure of the MICARES module, as shown in Table 2.

Table 2. Gas Module Packet Structure.

Field	TOS	XMesh	XSensor	Payload	CRC
Size (B)	5	0-7	4	18	2

The TinyOS standard header (5 bytes) includes: Destination address (2 bytes), Active Message handler ID (1 byte), Group ID (1 byte), Message length (1 byte).

The XMesh header is used to implement the multi-hop mesh system of the sensor network. The XSensor header is used for simplified communication between one node and the base station with no networking. The variable payload includes in our case the gas sensor values are represented as little endian 2 byte values. The cyclic redundancy check (CRC) of 2 bytes concludes the packet and assures data integrity. The aim is to keep packet size to a minimum because larger sizes decrease the probability of successful transmissions and therefore lead to resending the packets, increasing energy consumption of the node and network congestion. For a gas sensing node connected to the sink with a single hop in a laboratory environment, the following network statistics, listed in Table 3, were achieved.

Table 3. Radio Packet Statistics.

Node	Health	PRR	Drop	Cost	RSSI
105	1.83 %	98.37 %	1.63 %	4	42

Previous work estimated the overhead of the network, computed as the ratio between total network packets to data packets at 187 % [13]. This includes the messages issued to assure the correct behaviour of the network such as acknowledgements, route updates, time synchronization, other base station broadcasts and retransmissions. Optimization of the networking protocol has a significant impact on the

energy efficiency at the node and network level [14] a critical task when operating distributed measurement systems based on wireless sensor networks.

## 5. Conclusions

This paper described the design of a sensor node expansion module for gas sensing applications as a building block for a large scale indoor gas monitoring wireless sensor network. The main focus was to integrate this development with the MICA family, through the dedicated 51-pin connector, adopted widely by the scientific community. By integrating wireless gas sensor networks with building management systems and existing alarm infrastructure, dangerous situations can be signaled in a timely fashion and occupant quality of life and productivity can be enhanced.

Future work is centered around identifying the optimal operating mode in order to achieve autonomous operation by using batteries, renewable sources or energy harvesting techniques. Also an experimental set-up will be designed and implemented to enable the calibration of the low-cost gas sensors and offer reliable absolute gas concentration measurements. This can be implemented for both direct and indirect calibration methods in relationship to reference precision measurement devices or, already calibrated, neighboring nodes in the wireless sensor network. The electrical design of the expansion module is also subject to improvement as well as the embedded software controlling the on-board electrochemical gas sensors.

## Acknowledgements

The work has been partially funded by the Sectoral Operational Programme Human Resources Development 2007-2013 of the Ministry of European Funds through the Financial Agreement POSDRU/159/1.5/S/134398.

## References

- [1]. M. Strutu and D. Popescu, Indoor monitoring applications using fixed and mobile wireless sensors, *International Journal of Computing*, Vol. 10, No. 4, 2011, pp. 373–382.
- [2]. G. Stamatescu, D. Popescu, V. Sgarciu, MICARES: Mote expansion module for gas sensing applications, in *Proceedings of the 7<sup>th</sup> IEEE International Conference on Intelligent Data Acquisition and Advanced Computing Systems (IDAACS)*, Vol. 01, 12-14 September 2013, pp. 504-508.
- [3]. R. Seifert, H. Keller, J. Matthes, A Review on Innovative Procedures for the Analysis of Data from Gas Sensor Systems and Networks, *Sensors & Transducers*, Vol. 184, Issue 1, January 2015, pp. 1-10.
- [4]. C. Alippi, G. Anastasi, M. Di Francesco, and M. Roveri, Energy management in wireless sensor networks with energy-hungry sensors, *IEEE Instrumentation Measurement Magazine*, Vol. 12, No. 2, 2009, pp. 16–23.
- [5]. V. Jelcic, M. Magno, D. Brunelli, G. Paci, L. Benini, Context-Adaptive Multimodal Wireless Sensor Network for Energy-Efficient Gas Monitoring, *IEEE Sensors Journal*, Vol. 13, No. 1, Jan. 2013, pp. 328-338.
- [6]. A. Somov, A. Baranov, A. Savkin, D. Spirjakin, A. Spirjakin, and R. Passerone, Development of wireless sensor network for combustible gas monitoring, *Sensors and Actuators, A: Physical*, Vol. 171, No. 2, 2011, pp. 398–405.
- [7]. D. Hasenfratz, O. Saukh, and L. Thiele, On-the-fly calibration of low-cost gas sensors, in *Proceedings of the 9<sup>th</sup> European Conference on Wireless Sensor Networks (EWSN'12)*, 2012, pp. 228–244.
- [8]. Libelium, Gases Board - Technical Guide, Libelium, Technical Report, 2013, Available online: <http://www.libelium.com/development/waspmote/documentation/gases-board-technical-guide/>.
- [9]. MPR-MIB User's Manual, Revision a ed., Crossbow, Inc., 2007.
- [10]. XMesh User's Manual, Revision c ed., Crossbow, Inc., 2007.
- [11]. M. Turon, MOTE-VIEW: A Sensor Network Monitoring and Management Tool, *The Second IEEE Workshop on Embedded Networked Sensors (EmNetS-II)*, 30-31 May 2005, pp. 11-18.
- [12]. C. Alippi, G. Anastasi, M. Di Francesco, and M. Roveri, An adaptive sampling algorithm for effective energy management in wireless sensor networks with energy-hungry sensors, *IEEE Transactions on Instrumentation and Measurement*, Vol. 59, No. 2, 2010, pp. 335–344.
- [13]. G. Stamatescu and V. Sgarciu, Evaluation of wireless sensor network monitoring for indoor spaces, in *Proceedings of the International Symposium on Instrumentation Measurement, Sensor Network and Automation (IMSNA)*, Vol. 1, 2012, pp. 107–111.
- [14]. G. Stamatescu, C. Chitu, C. Vasile, I. Stamatescu, D. Popescu, V. Sgarciu, Analytical and experimental sensor node energy modeling in ambient monitoring, in *Proceedings of the 9<sup>th</sup> IEEE Conference on Industrial Electronics and Applications (ICIEA)*, 9-11 June 2014, pp. 1615-1620.