

ISSN 1726-5479

# SENSORS & TRANSDUCERS

vol. 101  
**2**/09

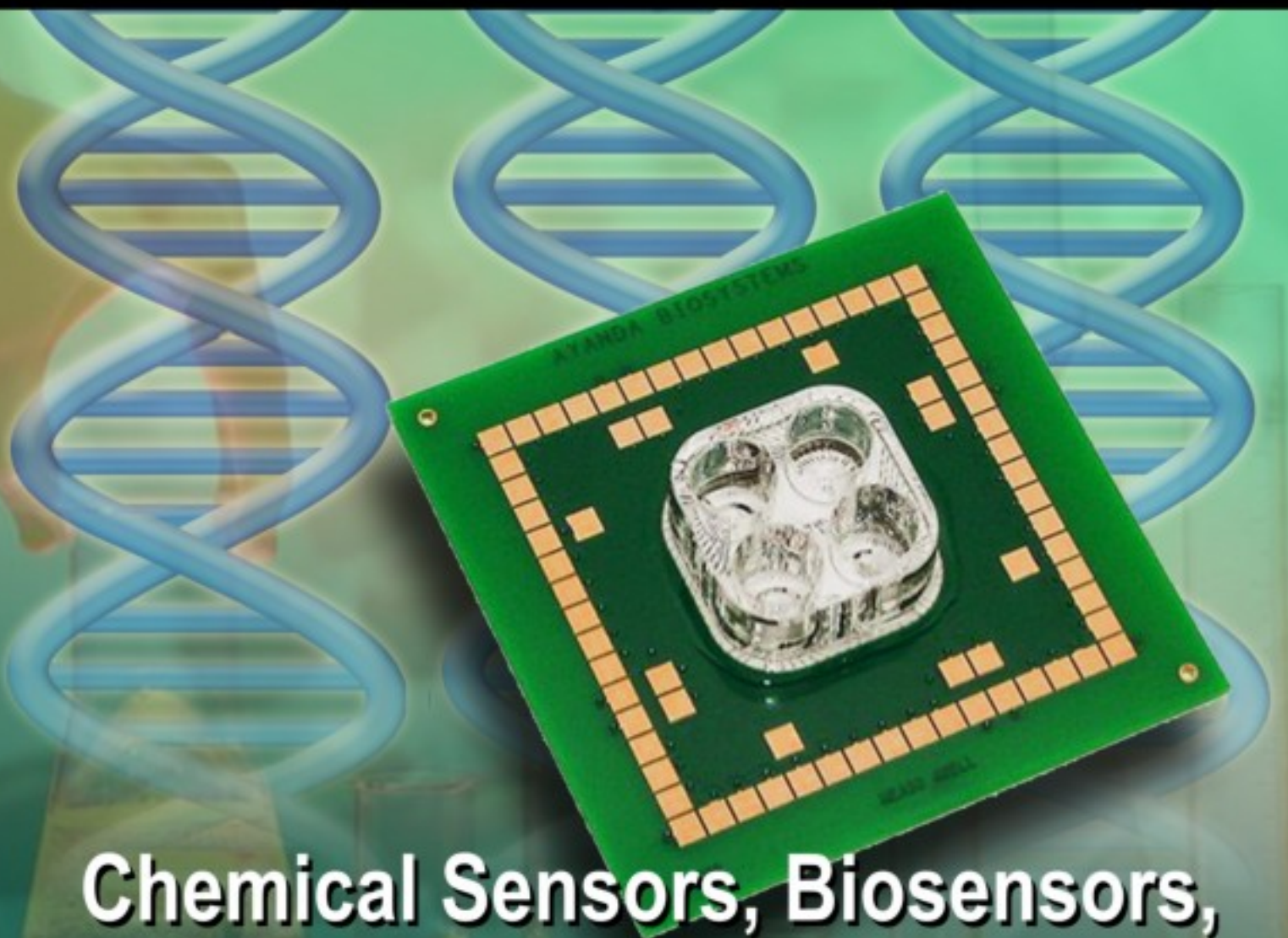

## Chemical Sensors, Biosensors, BioMEMS, Lab-on-Chip

International Frequency Sensor Association Publishing





# Sensors & Transducers

Volume 101  
February 2009

www.sensorsportal.com

ISSN 1726-5479

**Editor-in-Chief:** professor Sergey Y. Yurish, phone: +34 696067716, fax: +34 93 4011989, e-mail: editor@sensorsportal.com

**Editors for Western Europe**

Meijer, Gerard C.M., Delft University of Technology, The Netherlands  
Ferrari, Vittorio, Università di Brescia, Italy

**Editor South America**

Costa-Felix, Rodrigo, Inmetro, Brazil

**Editor for Eastern Europe**

Sachenko, Anatoly, Ternopil State Economic University, Ukraine

**Editors for North America**

Datskos, Panos G., Oak Ridge National Laboratory, USA  
Fabien, J. Josse, Marquette University, USA  
Katz, Evgeny, Clarkson University, USA

**Editor for Asia**

Ohyama, Shinji, Tokyo Institute of Technology, Japan

**Editor for Asia-Pacific**

Mukhopadhyay, Subhas, Massey University, New Zealand

## Editorial Advisory Board

- Abdul Rahim, Ruzairi**, Universiti Teknologi, Malaysia  
**Ahmad, Mohd Noor**, Northern University of Engineering, Malaysia  
**Annamalai, Karthigeyan**, National Institute of Advanced Industrial Science and Technology, Japan  
**Arcega, Francisco**, University of Zaragoza, Spain  
**Arguel, Philippe**, CNRS, France  
**Ahn, Jae-Pyoung**, Korea Institute of Science and Technology, Korea  
**Arndt, Michael**, Robert Bosch GmbH, Germany  
**Ascoli, Giorgio**, George Mason University, USA  
**Atalay, Selcuk**, Inonu University, Turkey  
**Atghiaee, Ahmad**, University of Tehran, Iran  
**Augutis, Vyantas**, Kaunas University of Technology, Lithuania  
**Avachit, Patil Lalchand**, North Maharashtra University, India  
**Ayesh, Aladdin**, De Montfort University, UK  
**Bahreyni, Behraad**, University of Manitoba, Canada  
**Baoxian, Ye**, Zhengzhou University, China  
**Barford, Lee**, Agilent Laboratories, USA  
**Barlingay, Ravindra**, RF Arrays Systems, India  
**Basu, Sukumar**, Jadavpur University, India  
**Beck, Stephen**, University of Sheffield, UK  
**Ben Bouzid, Sihem**, Institut National de Recherche Scientifique, Tunisia  
**Benachaiba, Chellali**, Universitaire de Bechar, Algeria  
**Binnie, T. David**, Napier University, UK  
**Bischoff, Gerlinde**, Inst. Analytical Chemistry, Germany  
**Bodas, Dhananjay**, IMTEK, Germany  
**Borges Carval, Nuno**, Universidade de Aveiro, Portugal  
**Bousbia-Salah, Mounir**, University of Annaba, Algeria  
**Bouvet, Marcel**, CNRS – UPMC, France  
**Brudzewski, Kazimierz**, Warsaw University of Technology, Poland  
**Cai, Chenxin**, Nanjing Normal University, China  
**Cai, Qingyun**, Hunan University, China  
**Campanella, Luigi**, University La Sapienza, Italy  
**Carvalho, Vitor**, Minho University, Portugal  
**Cecelja, Franjo**, Brunel University, London, UK  
**Cerda Belmonte, Judith**, Imperial College London, UK  
**Chakrabarty, Chandan Kumar**, Universiti Tenaga Nasional, Malaysia  
**Chakravorty, Dipankar**, Association for the Cultivation of Science, India  
**Changhai, Ru**, Harbin Engineering University, China  
**Chaudhari, Gajanan**, Shri Shivaji Science College, India  
**Chen, Jiming**, Zhejiang University, China  
**Chen, Rongshun**, National Tsing Hua University, Taiwan  
**Cheng, Kuo-Sheng**, National Cheng Kung University, Taiwan  
**Chiang, Jeffrey (Cheng-Ta)**, Industrial Technol. Research Institute, Taiwan  
**Chiriac, Horia**, National Institute of Research and Development, Romania  
**Chowdhuri, Arijit**, University of Delhi, India  
**Chung, Wen-Yaw**, Chung Yuan Christian University, Taiwan  
**Corres, Jesus**, Universidad Publica de Navarra, Spain  
**Cortes, Camilo A.**, Universidad Nacional de Colombia, Colombia  
**Courtois, Christian**, Universite de Valenciennes, France  
**Cusano, Andrea**, University of Sannio, Italy  
**D'Amico, Arnaldo**, Università di Tor Vergata, Italy  
**De Stefano, Luca**, Institute for Microelectronics and Microsystem, Italy  
**Deshmukh, Kiran**, Shri Shivaji Mahavidyalaya, Barshi, India  
**Dickert, Franz L.**, Vienna University, Austria  
**Dieguez, Angel**, University of Barcelona, Spain  
**Dimitropoulos, Panos**, University of Thessaly, Greece  
**Ding Jian, Ning**, Jiangsu University, China  
**Djordjević, Alexander**, City University of Hong Kong, Hong Kong  
**Donato, Nicola**, University of Messina, Italy  
**Donato, Patricio**, Universidad de Mar del Plata, Argentina  
**Dong, Feng**, Tianjin University, China  
**Drljaca, Predrag**, Instersema Sensoric SA, Switzerland  
**Dubey, Venketesh**, Bournemouth University, UK  
**Enderle, Stefan**, University of Ulm and KTB Mechatronics GmbH, Germany  
**Erdem, Gursan K. Arzum**, Ege University, Turkey  
**Erkmen, Aydan M.**, Middle East Technical University, Turkey  
**Estelle, Patrice**, Insa Rennes, France  
**Estrada, Horacio**, University of North Carolina, USA  
**Faiz, Adil**, INSA Lyon, France  
**Fericean, Sorin**, Balluff GmbH, Germany  
**Fernandes, Joana M.**, University of Porto, Portugal  
**Francioso, Luca**, CNR-IMM Institute for Microelectronics and Microsystems, Italy  
**Francis, Laurent**, University Catholique de Louvain, Belgium  
**Fu, Weiling**, South-Western Hospital, Chongqing, China  
**Gaura, Elena**, Coventry University, UK  
**Geng, Yanfeng**, China University of Petroleum, China  
**Gole, James**, Georgia Institute of Technology, USA  
**Gong, Hao**, National University of Singapore, Singapore  
**Gonzalez de la Rosa, Juan Jose**, University of Cadiz, Spain  
**Granel, Annette**, Goteborg University, Sweden  
**Graff, Mason**, The University of Texas at Arlington, USA  
**Guan, Shan**, Eastman Kodak, USA  
**Guillet, Bruno**, University of Caen, France  
**Guo, Zhen**, New Jersey Institute of Technology, USA  
**Gupta, Narendra Kumar**, Napier University, UK  
**Hadjiloucas, Sillas**, The University of Reading, UK  
**Hashsham, Syed**, Michigan State University, USA  
**Hernandez, Alvaro**, University of Alcalá, Spain  
**Hernandez, Wilmar**, Universidad Politecnica de Madrid, Spain  
**Homentcovschi, Dorel**, SUNY Binghamton, USA  
**Horstman, Tom**, U.S. Automation Group, LLC, USA  
**Hsiai, Tzung (John)**, University of Southern California, USA  
**Huang, Jeng-Sheng**, Chung Yuan Christian University, Taiwan  
**Huang, Star**, National Tsing Hua University, Taiwan  
**Huang, Wei**, PSG Design Center, USA  
**Hui, David**, University of New Orleans, USA  
**Jaffrezic-Renault, Nicole**, Ecole Centrale de Lyon, France  
**Jaime Calvo-Galleg, Jaime**, Universidad de Salamanca, Spain  
**James, Daniel**, Griffith University, Australia  
**Janting, Jakob**, DELTA Danish Electronics, Denmark  
**Jiang, Liudi**, University of Southampton, UK  
**Jiang, Wei**, University of Virginia, USA  
**Jiao, Zheng**, Shanghai University, China  
**John, Joachim**, IMEC, Belgium  
**Kalach, Andrew**, Voronezh Institute of Ministry of Interior, Russia  
**Kang, Moonho**, Sunmoon University, Korea South  
**Kaniusas, Eugenijus**, Vienna University of Technology, Austria  
**Katake, Anup**, Texas A&M University, USA  
**Kausel, Wilfried**, University of Music, Vienna, Austria  
**Kavasoglu, Nese**, Mugla University, Turkey  
**Ke, Cathy**, Tyndall National Institute, Ireland  
**Khan, Asif**, Aligarh Muslim University, Aligarh, India  
**Kim, Min Young**, Koh Young Technology, Inc., Korea South  
**Sandacci, Serghei**, Sensor Technology Ltd., UK

- Ko, Sang Choon**, Electronics and Telecommunications Research Institute, Korea South
- Kockar, Hakan**, Balikesir University, Turkey
- Kotulska, Malgorzata**, Wroclaw University of Technology, Poland
- Kratz, Henrik**, Uppsala University, Sweden
- Kumar, Arun**, University of South Florida, USA
- Kumar, Subodh**, National Physical Laboratory, India
- Kung, Chih-Hsien**, Chang-Jung Christian University, Taiwan
- Lacnjevac, Caslav**, University of Belgrade, Serbia
- Lay-Ekuakille, Aime**, University of Lecce, Italy
- Lee, Jang Myung**, Pusan National University, Korea South
- Lee, Jun Su**, Amkor Technology, Inc. South Korea
- Lei, Hua**, National Starch and Chemical Company, USA
- Li, Genxi**, Nanjing University, China
- Li, Hui**, Shanghai Jiaotong University, China
- Li, Xian-Fang**, Central South University, China
- Liang, Yuanchang**, University of Washington, USA
- Liawruangrath, Saisune**, Chiang Mai University, Thailand
- Liew, Kim Meow**, City University of Hong Kong, Hong Kong
- Lin, Hermann**, National Kaohsiung University, Taiwan
- Lin, Paul**, Cleveland State University, USA
- Linderholm, Pontus**, EPFL - Microsystems Laboratory, Switzerland
- Liu, Aihua**, University of Oklahoma, USA
- Liu Changgeng**, Louisiana State University, USA
- Liu, Cheng-Hsien**, National Tsing Hua University, Taiwan
- Liu, Songqin**, Southeast University, China
- Lodeiro, Carlos**, Universidade NOVA de Lisboa, Portugal
- Lorenzo, Maria Encarnacio**, Universidad Autonoma de Madrid, Spain
- Lukaszewicz, Jerzy Pawel**, Nicholas Copernicus University, Poland
- Ma, Zhanfang**, Northeast Normal University, China
- Majstorovic, Vidosav**, University of Belgrade, Serbia
- Marquez, Alfredo**, Centro de Investigacion en Materiales Avanzados, Mexico
- Matay, Ladislav**, Slovak Academy of Sciences, Slovakia
- Mathur, Prafull**, National Physical Laboratory, India
- Maurya, D.K.**, Institute of Materials Research and Engineering, Singapore
- Mekid, Samir**, University of Manchester, UK
- Melnyk, Ivan**, Photon Control Inc., Canada
- Mendes, Paulo**, University of Minho, Portugal
- Mennell, Julie**, Northumbria University, UK
- Mi, Bin**, Boston Scientific Corporation, USA
- Minas, Graca**, University of Minho, Portugal
- Moghavvemi, Mahmoud**, University of Malaya, Malaysia
- Mohammadi, Mohammad-Reza**, University of Cambridge, UK
- Molina Flores, Esteban**, Benemérita Universidad Autónoma de Puebla, Mexico
- Moradi, Majid**, University of Kerman, Iran
- Morello, Rosario**, DIMET, University "Mediterranea" of Reggio Calabria, Italy
- Mounir, Ben Ali**, University of Sousse, Tunisia
- Mulla, Imtiaz Sirajuddin**, National Chemical Laboratory, Pune, India
- Neelamegam, Periasamy**, Sastra Deemed University, India
- Neshkova, Milka**, Bulgarian Academy of Sciences, Bulgaria
- Oberhammer, Joachim**, Royal Institute of Technology, Sweden
- Ould Lahoucine, Cherif**, University of Guelma, Algeria
- Pamidighanta, Sayanu**, Bharat Electronics Limited (BEL), India
- Pan, Jisheng**, Institute of Materials Research & Engineering, Singapore
- Park, Joon-Shik**, Korea Electronics Technology Institute, Korea South
- Penza, Michele**, ENEA C.R., Italy
- Pereira, Jose Miguel**, Instituto Politecnico de Setebal, Portugal
- Petsev, Dimiter**, University of New Mexico, USA
- Pogacnik, Lea**, University of Ljubljana, Slovenia
- Post, Michael**, National Research Council, Canada
- Prance, Robert**, University of Sussex, UK
- Prasad, Ambika**, Gulbarga University, India
- Prateepasen, Asa**, Kingmoungut's University of Technology, Thailand
- Pullini, Daniele**, Centro Ricerche FIAT, Italy
- Pumera, Martin**, National Institute for Materials Science, Japan
- Radhakrishnan, S.**, National Chemical Laboratory, Pune, India
- Rajanna, K.**, Indian Institute of Science, India
- Ramadan, Qasem**, Institute of Microelectronics, Singapore
- Rao, Basuthkar**, Tata Inst. of Fundamental Research, India
- Raouf, Kosai**, Joseph Fourier University of Grenoble, France
- Reig, Candid**, University of Valencia, Spain
- Restivo, Maria Teresa**, University of Porto, Portugal
- Robert, Michel**, University Henri Poincare, France
- Rezazadeh, Ghader**, Urmia University, Iran
- Royo, Santiago**, Universitat Politècnica de Catalunya, Spain
- Rodriguez, Angel**, Universidad Politécnica de Catalunya, Spain
- Rothberg, Steve**, Loughborough University, UK
- Sadana, Ajit**, University of Mississippi, USA
- Sadeghian Marnani, Hamed**, TU Delft, The Netherlands
- Sapozhnikova, Ksenia**, D.I.Mendeleyev Institute for Metrology, Russia
- Saxena, Vibha**, Bhabha Atomic Research Centre, Mumbai, India
- Schneider, John K.**, Ultra-Scan Corporation, USA
- Seif, Selemeni**, Alabama A & M University, USA
- Seifter, Achim**, Los Alamos National Laboratory, USA
- Sengupta, Deepak**, Advance Bio-Photonics, India
- Shankar, B. Baliga**, General Monitors Transnational, USA
- Shearwood, Christopher**, Nanyang Technological University, Singapore
- Shin, Kyuho**, Samsung Advanced Institute of Technology, Korea
- Shmaliy, Yuriy**, Kharkiv National University of Radio Electronics, Ukraine
- Silva Girao, Pedro**, Technical University of Lisbon, Portugal
- Singh, V. R.**, National Physical Laboratory, India
- Slomovitz, Daniel**, UTE, Uruguay
- Smith, Martin**, Open University, UK
- Soleymanpour, Ahmad**, Damghan Basic Science University, Iran
- Somani, Prakash R.**, Centre for Materials for Electronics Technol., India
- Srinivas, Talabattula**, Indian Institute of Science, Bangalore, India
- Srivastava, Arvind K.**, Northwestern University, USA
- Stefan-van Staden, Raluca-Ioana**, University of Pretoria, South Africa
- Sumriddetchka, Sarun**, National Electronics and Computer Technology Center, Thailand
- Sun, Chengliang**, Polytechnic University, Hong-Kong
- Sun, Dongming**, Jilin University, China
- Sun, Junhua**, Beijing University of Aeronautics and Astronautics, China
- Sun, Zhiqiang**, Central South University, China
- Suri, C. Raman**, Institute of Microbial Technology, India
- Sysoev, Victor**, Saratov State Technical University, Russia
- Szewczyk, Roman**, Industrial Research Institute for Automation and Measurement, Poland
- Tan, Ooi Kiang**, Nanyang Technological University, Singapore,
- Tang, Dianping**, Southwest University, China
- Tang, Jaw-Luen**, National Chung Cheng University, Taiwan
- Teker, Kasif**, Frostburg State University, USA
- Thumbavanam Pad, Kartik**, Carnegie Mellon University, USA
- Tian, Gui Yun**, University of Newcastle, UK
- Tsiantos, Vassilios**, Technological Educational Institute of Kaval, Greece
- Tsigara, Anna**, National Hellenic Research Foundation, Greece
- Twomey, Karen**, University College Cork, Ireland
- Valente, Antonio**, University, Vila Real, - U.T.A.D., Portugal
- Vaseashta, Ashok**, Marshall University, USA
- Vazquez, Carmen**, Carlos III University in Madrid, Spain
- Vieira, Manuela**, Instituto Superior de Engenharia de Lisboa, Portugal
- Vigna, Benedetto**, STMicroelectronics, Italy
- Vrba, Radimir**, Brno University of Technology, Czech Republic
- Wandelt, Barbara**, Technical University of Lodz, Poland
- Wang, Jiangping**, Xi'an Shiyong University, China
- Wang, Kedong**, Beihang University, China
- Wang, Liang**, Advanced Micro Devices, USA
- Wang, Mi**, University of Leeds, UK
- Wang, Shinn-Fwu**, Ching Yun University, Taiwan
- Wang, Wei-Chih**, University of Washington, USA
- Wang, Wensheng**, University of Pennsylvania, USA
- Watson, Steven**, Center for NanoSpace Technologies Inc., USA
- Weiping, Yan**, Dalian University of Technology, China
- Wells, Stephen**, Southern Company Services, USA
- Wolkenberg, Andrzej**, Institute of Electron Technology, Poland
- Woods, R. Clive**, Louisiana State University, USA
- Wu, DerHo**, National Pingtung University of Science and Technology, Taiwan
- Wu, Zhaoyang**, Hunan University, China
- Xiu Tao, Ge**, Chuzhou University, China
- Xu, Lisheng**, The Chinese University of Hong Kong, Hong Kong
- Xu, Tao**, University of California, Irvine, USA
- Yang, Dongfang**, National Research Council, Canada
- Yang, Wuqiang**, The University of Manchester, UK
- Ymeti, Aurel**, University of Twente, Netherland
- Yong Zhao**, Northeastern University, China
- Yu, Haihu**, Wuhan University of Technology, China
- Yuan, Yong**, Massey University, New Zealand
- Yufera Garcia, Alberto**, Seville University, Spain
- Zagnoni, Michele**, University of Southampton, UK
- Zeni, Luigi**, Second University of Naples, Italy
- Zhong, Haoxiang**, Henan Normal University, China
- Zhang, Minglong**, Shanghai University, China
- Zhang, Quintao**, University of California at Berkeley, USA
- Zhang, Weiping**, Shanghai Jiao Tong University, China
- Zhang, Wenming**, Shanghai Jiao Tong University, China
- Zhou, Zhi-Gang**, Tsinghua University, China
- Zorzano, Luis**, Universidad de La Rioja, Spain
- Zourob, Mohammed**, University of Cambridge, UK

# Contents

Volume 101  
Issue 2  
February 2009

www.sensorsportal.com

ISSN 1726-5479

## Research Articles

- Preliminary Characterization of a Commercial Chiral Stationary Phase as a Selector for Chemical Sensor Applications Using a Quartz Crystal Microbalance**  
*W. J. Buttner, C-L. Lu, V. Perez-Luna, J. R. Stetter and G. K. Webster*..... 1
- New Copolymers Containing Charge Carriers for Organic Devices with ITO Films Treated by UV-Ozone Using High Intensity Discharge Lamp**  
*Emerson Roberto Santos, Fábio Conte Correia, Elvo Calixto Burini Junior, Shu Hui Wang, Marcia Akemi Yamasoe, Pilar Hidalgo, Fernando Josepetti Fonseca, Adnei Melges de Andrade* ..... 12
- Aquaregia and Oxygen Plasma Treatments on Fluorinated Tin Oxide for Assembly of PLEDs Devices Using OC1C10-PPV as Emissive Polymer**  
*Emerson Roberto Santos, Elvo Calixto Burini Junior, Fernando Josepetti Fonseca*..... 22
- Electrical Conduction and Humidity Sensing Properties of NiCr<sub>2</sub>O<sub>4</sub>-ZnO-CeO<sub>2</sub> Composites**  
*L. Regina Mary, K. S. Nagaraja*..... 31
- Humidity and Electrical Sensing Properties of NiCr<sub>2</sub>O<sub>4</sub>-ZnO-MnO<sub>2</sub> Composites**  
*Regina Mary L., Jeyaraj B. and Nagaraja K. S.*..... 42
- Poly (3, 4-Ethylenedioxythiophene) - Poly (4-Styrenesulfonate) for Humidity Sensing Using Ink-jet Printing Technique on Flexible Polyimide Substrate**  
*Hee C. Lim, Yew Fong Hor, Yew L. Hor, James L. Zunino III and John F. Federici*..... 52
- Cobalt Doped SnO<sub>2</sub> Thick Film Gas Sensors: Conductance and Gas Response Characteristics for LPG and CNG Gas**  
*V. Kumar, S. K. Srivastava, Kiran Jain*..... 60
- Study on Gas Sensing Performance of TiO<sub>2</sub> Screen Printed Thick Films**  
*C. G. Dighavkar, A. V. Patil and R. Y. Borse*..... 73
- Metal Oxides Doped PPY-PVA Blend Thin Films Based Gas Sensor**  
*D. B. Dupare, M. D. Shirsat and A. S. Aswar*..... 82
- Surface Morphology Dependent Copper Sulphide Ammonia Gas Sensor Working at Room Temperature: Effect of SHI Irradiation**  
*Ramphal Sharma, Abhay A. Sagade, J. C. Vyas, P. K. Nema, Anil Ghule and Sung-Hwan Han*.... 90
- NO<sub>2</sub> Gas Sensing Properties of Screen Printed ZnO Thick Films**  
*A. V. Patil, C. G. Dighavkar and R. Y. Borse*..... 96
- Loss of Capacitance Ideality in Label-Free Immuno-Chip**  
*Sandro Carrara, Vijayender Bhalla, Luca Benini, Bruno Samori* ..... 104
- Development of an Optical Urea Biosensor Using Polypyrrole-polyvinyl Sulphonate Film**  
*H. J. Kharat, K. Datta, P. Ghosh, Mahendra D. Shirsat* ..... 112

<b>Performance Comparison of SPR Sensors Based on Chalcogenide and Silica Glass Prisms</b> <i>Rajan Jha and Anuj K. Sharma .....</i>	123
<b>Non-invasive Blood Glucose Quantification Using a Hybrid Sensor</b> <i>Sundararajan Jayapal, Dr. V. Palanisamy, Sandeep Mandyam .....</i>	132

Authors are encouraged to submit article in MS Word (doc) and Acrobat (pdf) formats by e-mail: [editor@sensorsportal.com](mailto:editor@sensorsportal.com)  
Please visit journal's webpage with preparation instructions: <http://www.sensorsportal.com/HTML/DIGEST/Submission.htm>

## **New Copolymers Containing Charge Carriers for Organic Devices with ITO Films Treated by UV-Ozone Using High Intensity Discharge Lamp**

**Emerson Roberto SANTOS, Fábio Conte CORREIA, Elvo Calixto Burini JUNIOR, Shu Hui WANG, Marcia Akemi YAMASOE, Pilar HIDALGO, Fernando Josepetti FONSECA, Adnei Melges de ANDRADE**

Escola Politécnica da Universidade de São Paulo, Departamento de Sistemas Eletrônicos,  
05508-010, Cidade Universitária, São Paulo, SP, Brazil

Escola Politécnica da Universidade de São Paulo, Departamento de Engenharia Metalúrgica e de  
Materiais, 05508-900, Cidade Universitária, São Paulo, SP, Brazil

Instituto de Eletrotécnica e Energia da Universidade de São Paulo,  
05508-010, Cidade Universitária, São Paulo, SP, Brazil

Instituto de Astronomia, Geofísica e Ciência Atmosférica da Universidade de São Paulo,  
05508-900, Cidade Universitária, São Paulo, SP, Brazil

Tel.: ++55 (11) 3091-5302, fax: +55 (11) 3091-5585

E-mail: [emerson@lme.usp.br](mailto:emerson@lme.usp.br)

*Received: 22 January 2009 /Accepted: 20 February 2009 /Published: 28 February 2009*

---

**Abstract:** For electroluminescent devices new copolymers were synthesized using a Suzuki cross-coupling reaction based on monomers (fluorine-alt-phenylene) in conjugation with quinoline-alt-phenylene units. They were characterized by  $^1\text{H}$  NMR,  $^{13}\text{C}$  NMR and FTIR. TGA measurements indicated that the copolymers have good thermal properties and no weight loss was observed up to 250 °C. The UV-Vis spectra were characterized by absorptions from the fluorene-alt-phenylene and quinoline-alt-phenylene segments in the backbone, while their photoluminescence (PL) spectra dominated by emissions from the fluorene excimer. For devices assembly ITO films were treated using a High Intensity Discharge Lamp (HPMVL) without outer bulb presenting high ozone concentration than that conventional germicidal lamp. The device with ITO treated revealed significant decrease of threshold voltage (or turn-on voltage) compared by untreated with I-V curves. This decrease can be related by water and carbon dioxide extracted on surface after UV-Ozone treatment revealed by DRIFT measurements. *Copyright © 2009 IFSA.*

**Keywords:** Polymer, ITO, UV-Ozone, HID, Electroluminescence

## 1. Introduction

Polymers are widely used as electrical insulation due to its high electrical resistivity and easy processing. However, since 1963, when it was published the first work on the electrical conduction of conjugated polymers and by at the end of the 1980, it was reported for the first time the electroluminescence (EL) of this class of polymers we have had witnessed the increasing technological and scientific interest on this class of materials [1]. Polymers with fluorene group are very interesting material due to its high photoluminescence (PL), high quantum yields, thermal stability and good solubility. Quinoline is known for its conjugated structures and polymers bearing quinoline groups have been reported to portray a combination of enhanced electronic, optoelectronic or nonlinear optical properties along with excellent mechanical properties [2]. The growing interest in these polymers is due to their technological edge applications such as displays and low cost flat surface devices, good processability and possibility to adjust precisely the emission color. In the present work the Suzuki cross-coupling reaction was used [3]. The synthesis occurs in the presence of a complex formed with the catalyst, for instance palladium (tetrakis(triphenylphosphine)palladium)  $(P(Ph_3)_4Pd)$  in which carbon-carbon bonds are formed by coupling a compound containing a borate group and an organo-halide compound. After preparation of polymeric synthesis some devices were mounted. In the assembly of devices were used commercial indium tin oxide (ITO) films as anode deposited on glass due to its good electrical (low resistivity) and optical (transparency) [4]. On the ITO films were deposited: PEDOT:PSS (as Hole Transport Layer)/ copolymer (as emissive polymer described in the next section)/ aluminium (as cathode). Another aspect of great interest for these devices mounted in this work is threshold voltage (or turn-on voltage). To obtain better performance of devices is necessary to have a good emissive polymer or copolymer with surface of ITO film cleaned without undesirable elements [5]. In this work ITO films were treated by UV-Ozone reactor assembled with some components generating low cost. A new copolymer containing fluorene-quinoline groups on the treated ITO film was used. The ozone formed from atmospheric air can be explained by Chapman's cycle [6]:

**Table 1.** Formation and destruction of ozone by Chapman's cycle.

$O_2$ (atmospheric air) + $h\nu$ ( $\lambda < 243$ nm) $\rightarrow$ 2 $O\cdot$ (free radicals)	(1)	<b>Ozone formation</b>
$(O\cdot) + O_2 \rightarrow O_3$ (ozone)	(2)	
$O_3 + h\nu$ ( $240 < \lambda < 320$ nm) $\rightarrow$ $O_2 + O\cdot$	(3)	<b>Ozone destruction</b>
$(O\cdot) + O_3 \rightarrow 2 O_2$	(4)	

## 2. Experimental

### 2.1. Materials Used

All reagents were used as received from commercial sources (Aldrich or Acros) without further purification. The emissive polymer 5,7-dibromo-8-oxyoctyl-quinoline has been synthesized.

### 2.2. Preparation of Copolymers

The method used is described in the literature. The copolymers were synthesized from 1,4-phenylene-bisboronic acid, 1,4-dichlorobenzene, 5,7-dibromo-8-oxyoctyl-quinoline and 9,9-Dioctyl-2,7-dibromofluorene with tetrakis  $P(Ph_3)_4Pd$  as catalyst using two distinct synthetical assessments,

specifically using toluene solution and aqueous calcium carbonate and a modified procedure in which xylene solution and aqueous potassium carbonate, along with a phase transfer agent (benzalkonium chloride).

Shortly, in a dry box under nitrogen atmosphere, a reaction vessel was filled with 0.586 g (1.419 mmol) of 5,7-dibromo-8-oxyloctyl-quinoline, 0.334 g (1.017 mmol) of 1,4-phenylenebisboronic acid (Aldrich), 0.108 g (0.197 mmol) of 9,9-dioctyl-2,7-dibromofluorene (Aldrich, 99%), 0.058 g (0.394 mmol) of 1,4 dichlorobenzene (Vetec, 99 %), 0.034 g (0.034 mmol) of  $P(Ph_3)_4Pd$  (Acros, 99 %), all dissolved in toluene or xylene. An alkaline aqueous solution of calcium or potassium carbonate was then added and the reaction mixture was heated up to 100 °C and kept under magnetic stirring for 24 h. After purification 59 % and 88 % of yield were found for copolymer 1 and copolymer 2, respectively.  $^1H$  NMR ( $CDCl_3$ ): 8.92 – 8.97 (m, 1H, N-CH), 8.5 – 7.2 (m, 24H, Ar-H), 4.10 – 4.00 (m, 2H, O-CH<sub>2</sub>), 2.05 – 1.95 (m, 6H, CH<sub>2</sub>), 1.70 – 1.08(m, 34H, CH<sub>2</sub>), 0.89 – 0.77 (m, 9H, CH<sub>3</sub>).

### **2.3. Characterization of Copolymers**

$^1H$  Nuclear magnetic resonance spectra (200 MHz) were recorded using a Bruker AC-200 spectrometer with deuterium chloroform (Aldrich) as solvent and tetramethylsilane (TMS) as internal reference. The UV absorption spectra were collected by Varian equipment, Cary 50. Samples were dissolved in chloroform and the solution was poured into a 10 mm square quartz cell. The transmission spectrum was collected from 200 – 600 nm. The photoluminescence spectra (PL) in solution were determined using a Varian Eclipse fluorescence spectrophotometer. Samples were dissolved in chloroform and subjected to irradiation at the absorption maximum observed by UV spectroscopy and the emission spectra were collected accordingly. TGA (Thermogravimetric Analysis) curves were obtained using thermal gravimetric analyzer TGA-51 (Shimadzu) in the range from 50 to 800 °C by heating rate at 10 °C / min. under argon atmosphere.

### **2.4. Analyses of two different lamps for UV-Ozone generation**

For UV-Ozone generation were compared two different lamps: a high intensity discharge (HID) or also known as high-pressure mercury vapor lamp (HPMVL) and germicidal tubular fluorescent or also low-pressure mercury vapor lamp (LPMVL).

*HPMVL* – In the experiment this lamp type was chosen due to its high lifetime operation with  $\approx$  15,000 hours, low cost and only some components. In the experiment was used a HPMVL of 400 W with Edison screw without an outer bulb, only ignition tube (quartz tube) connected by aluminium reflector, fans near of wall tube and ballast plugged at local power (220V). The reflector with the lamp was placed upside down insulating ambient of the ultraviolet rays. In the Fig. 1, it is presented the reactor with HPMVL.

*LPMVL* - In the experiment was used a germicidal fluorescent tubular lamp presenting high lifetime with  $\approx$  6,000 hours. This lamp type was also chosen due to its main application of germicidal or sterilization effects destroying bacteria, viruses, mold spores and another organisms. In the experiment was used a LPMVL of 15 W and ballast plugged at local power (110V).



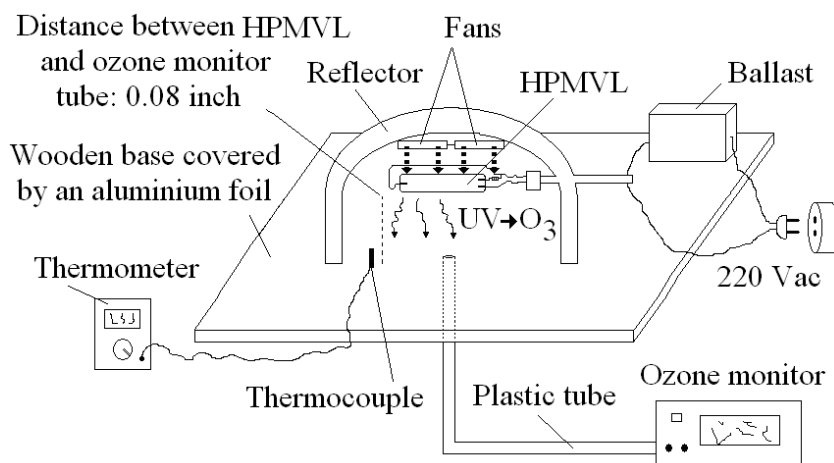

**Fig. 1.** Reactor mounted with HPMVL and some components for UV-Ozone generation.

This lamp type generally irradiates in specific band of wavelength at 254 nm presenting 100 % of maximum germicidal effectiveness and causing photo-oxidation reactions [7]. How these lamps can cause inflammation or irritation of skin and eyes is necessary to isolate of any closed room. It was connected by electric contacts on wooden base placed into black tube plastic sealed at the two ends. In the Fig. 2, it is presented the reactor with LPMVL.

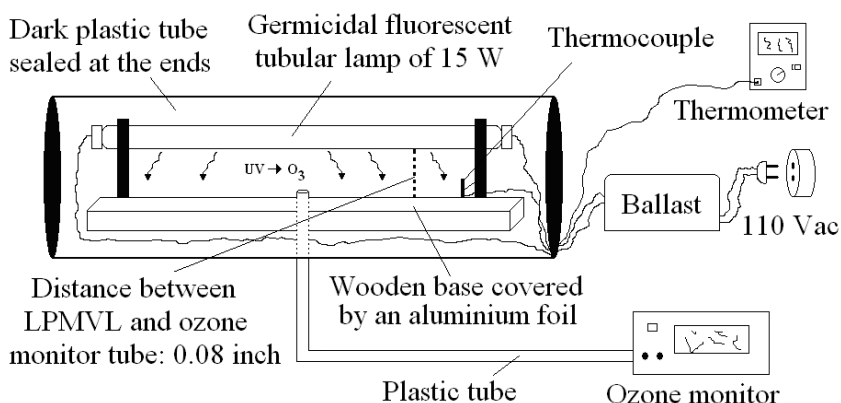

**Fig. 2.** Reactor mounted with LPMVL and some components for UV-Ozone generation.

The ozone generated by each lamp was collected although of plastic tube connected between reactor and ozone concentration monitor manufactured by In DevR 2B Technologies model 205. A thermometer manufactured by Minipa was also used with thermocouple placed near of the wall lamps monitoring the temperature.

## 2.5. Preparation of Devices

For preparation of devices with ITO films deposited on glass substrates, the samples were cut in sizes of 1 in<sup>2</sup>. Then the samples were pre-cleaned first into acetone and isopropyl alcohol both each 30 minutes/finally dried with nitrogen flow. After pre-cleaning the substrates were irradiated with UV-Ozone reactor using only HID lamp during 5 minutes.

In assembly of electroluminescent devices polymer and copolymer layers were deposited on ITO films with spin-coating technique by 1,500 RPM by 30 seconds. First was deposited a hole transport layer (HTL) of poly (3,4-ethylenedioxythiophene) doped with poly (styrenesulfonate) (PEDOT:PSS) with  $\approx 50$  nm thick and annealing by 1 hour at 100 °C and emissive film with copolymer with  $\approx 120$  nm thick and annealing during 1 day at 50 °C in vacuum both were filtered with 1  $\mu$ m porous. The cathode electrode with an aluminium layer  $\approx 500$  nm thick was thermally evaporated on emissive copolymer. The obtained results were compared between treated and an untreated samples with the analysis revealing influences of treatment on devices.

### 3. Results and Discussion

#### 3.1. Copolymer Analysis

Fig. 3 shows the  $^1\text{H}$  nuclear magnetic resonance spectrum of the copolymer 2. This spectrum was separated into regions to better identification of the peaks. Thus 6 regions were identified; the first region corresponds to the proton more shielded of the end of the alifatic moiety  $\text{CH}_3$ . The regions 2 and 3 correspond to the methylene protons  $\text{CH}_2$ . Meanwhile, the oxy-methylene protons of the quinoline are in the region 4. The decline in shielding occurs by the proximity of oxygen.

Protons of aromatic rings are shown in region 5 and finally the region 6 corresponds to the deshielded proton on the carbon adjacent to nitrogen.

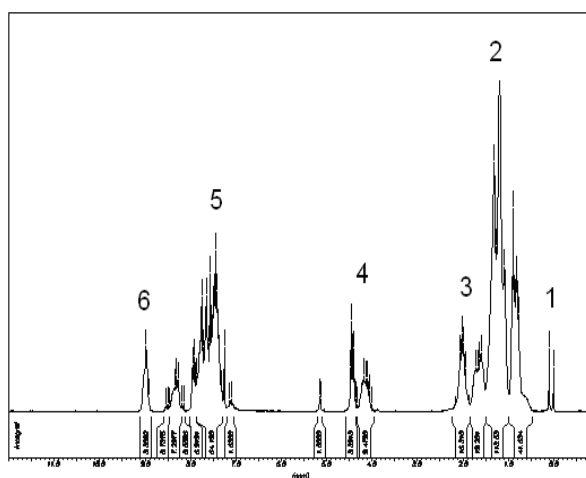

**Fig. 3.**  $^1\text{H}$  NMR spectrum of copolymer 2.

Fig. 4 shows the TGA curves of the copolymers 1 and 2, in the temperature range from 50 to 800 °C. The copolymer 2 presented three steps of degradation. At 250 °C the copolymers begin to decompose. At 386 °C the second step of the degradation of the copolymer and 480 °C the third step.

Fig. 5 shows the absorption spectra of the copolymers 1 and 2 in  $\text{CHCl}_3$ . We may notice that for the same molar concentration, both copolymers showed absorption maxima at 250, 280 and 315 nm, varying, however, in their intensity. The intense absorption around 250 nm is due to the phenylene groups of the backbone, while fluorene and quinoline are characterized by absorptions at 282 and 314 nm and 310 nm, respectively.

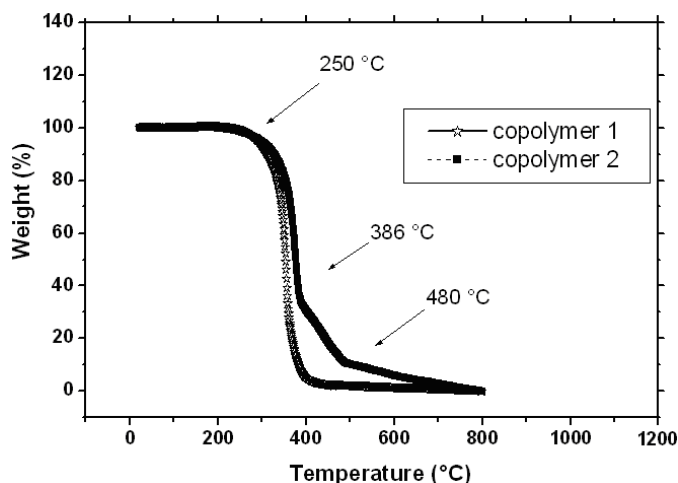

**Fig. 4.** Thermal gravimetric analyses of the copolymers.

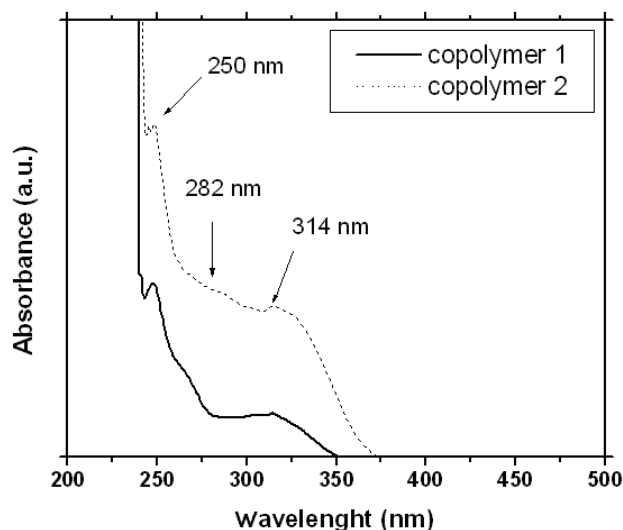

**Fig. 5.** Absorption spectra of the copolymers.

Fig. 6 shows the fluorescence spectra of copolymers 1 and 2 in  $\text{CHCl}_3$ . Both copolymers showed a maximum peak of emission at 419 nm due to fluorene groups, with a little variation in their intensity. No significant emission was observed for phenylene and quinoline groups.

### 3.2. Lamps Analysis

Fig. 7 shows the ozone concentration vs. time and Fig. 8 shows the temperature vs. time both obtained during eight times in two-by-two minutes until 60 minutes. The arithmetic medium for each point were obtained.

HID lamp presented a faster maximum peak of 0 to 63,000 ppm of ozone concentration during the first 10 minutes of radiation and it shown a decrease to 60 minutes. A possible hypothesis for this behavior can be explained by decreasing of the oxygen amount generated by air inside of reflector that may have been consumed during successive cycles (Chapman's cycle) for ozone formation and also forming sub products of chemical reaction.

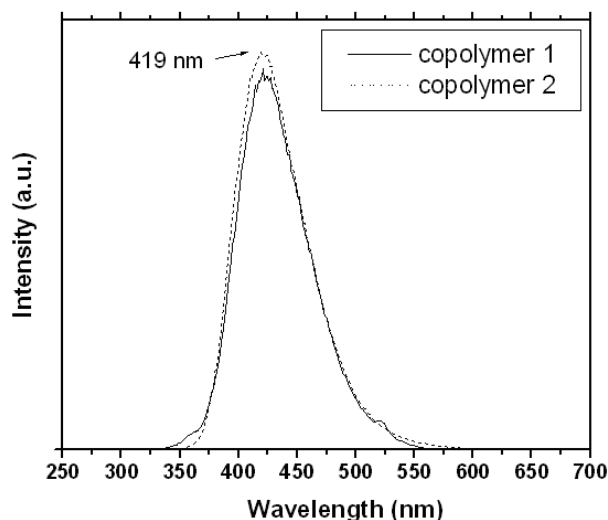

Fig. 6. Fluorescence spectra in  $\text{CHCl}_3$  of the copolymers.

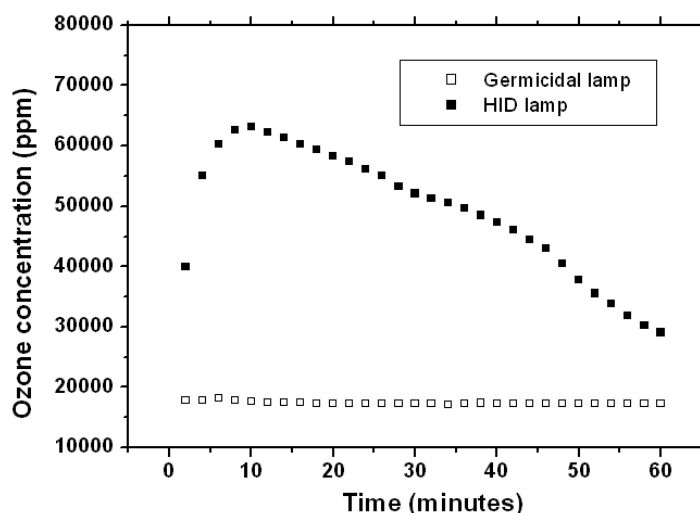

Fig. 7. Ozone concentration vs. time for HID and germicidal analyzed lamps.

Germicidal lamp presented lowest ozone concentration of 0 to 17,000 ppm during all the time of the radiation. Another hypothesis for this behavior can be explained by temperature effect. The germicidal lamp presented temperatures at the 38 °C with low variation, while the HID presented at the 95 °C using fans for maximum time of 60 minutes. The effect of temperature in this case can also contribute with the ozone formation by air atmospheric independent of lamp used.

In the literature is related maximum temperature at 40 °C for better germicidal efficiency of 100 % but it did not report the amount of ozone produced.

The PLEDs assembly was used the HPMVL for generation of UV-Ozone on ITO films and emissive layer with copolymer 2.

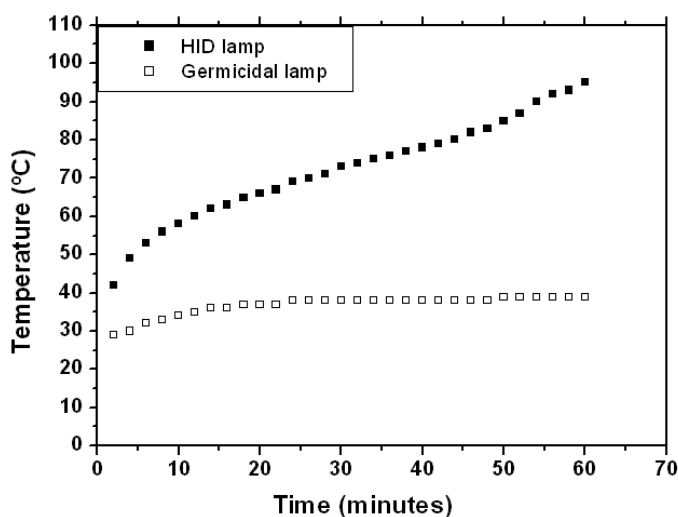

Fig. 8. Temperature vs. time for HID and germicidal analyzed lamps.

Fig. 9 shows the forward bias by current vs. voltage curves for PLEDs devices with ITO films of  $85 \Omega/\text{square}$  treated by 5 minutes of UV-Ozone and compared with an untreated sample. The sample treated revealed significant decrease in the threshold voltage (or turn-on voltage) by straight tangent to the curves reaching  $\approx 5 \text{ V}$  for treated sample and  $\approx 13.5 \text{ V}$  for an untreated sample.

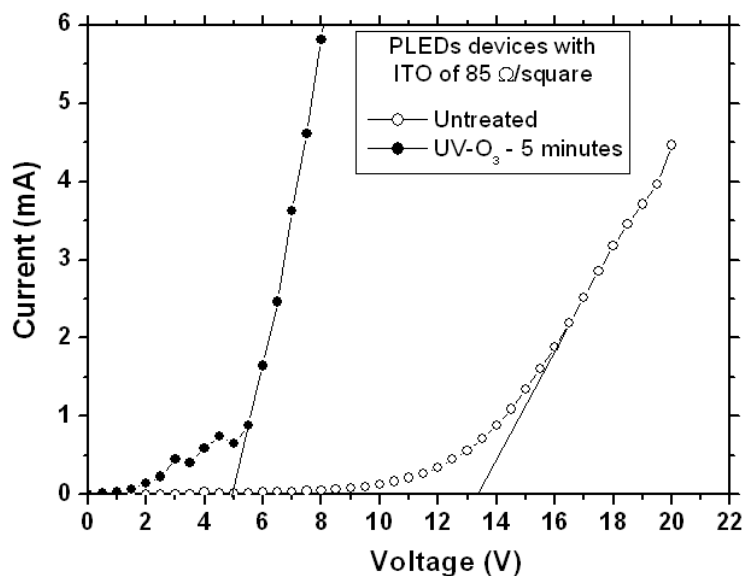
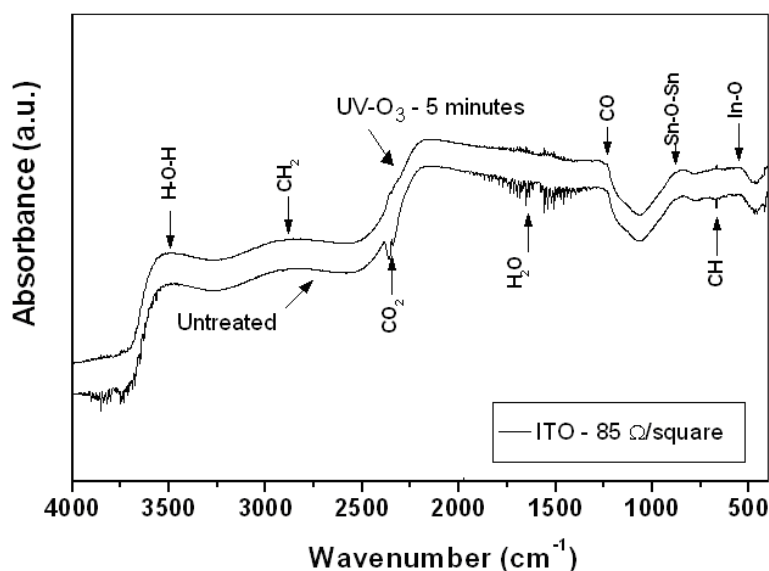

Fig. 9. I-V curves for electroluminescent devices using ITO untreated and treated by 5 minutes of UV-O<sub>3</sub>.

Fig. 10 shows the DRIFT (Diffuse Reflectance by Infra-Red Fourier Transformed) technique results. A sample was measured before of treatment and consequently treated by 5 minutes. Before treatment the analysis revealed on surface of ITO film the presence of water and carbon dioxide and after treatment was verified that these elements were eliminated.



**Fig. 10.** DRIFT analysis for same sample before an untreated and after treated by 5 minutes of UV-O<sub>3</sub>.

In this experiment was not possible to obtain the luminance of the devices, but a significant change in the surface of ITO film was obtained with the elimination of carbon or hydrocarbon that increases the performance of device treated by 5 minutes as reported in the literature using UV-Ozone with other lamps, commercial equipments or also other methods of treatment [8, 9].

#### 4. Conclusions

Comparative analysis of reactions has shown interesting results indicating fast growth of the chain and, consequently, also an increase in the molar mass of the copolymers prepared by the second route. In that method, it was noticed besides the high yield (>88 %), higher molar mass and during the reaction the solution already presented high viscosity. Compared to the copolymer synthesized by the traditional route, it has been demonstrated improvement in the reaction efficiency. The devices showed no emission of light but presented the typical I-V curves of polymer/organic light emitting diodes.

A new procedure of UV-Ozone treatment using HID lamp was carried out producing highest ozone concentration than that germicidal lamp. For this motive the HID lamp was used for treatment revealing significant difference between an untreated sample and treated by 5 minutes observed by voltage threshold (or turn-on voltage) in the I-V curves. DRIFT measurements revealed the elimination of carbon and hydrocarbon as report in the literature with UV-Ozone using other lamps, commercial equipments or also other techniques of treatment.

#### Acknowledgements

Thank to Ministério da Ciência e Tecnologia, CNPq, Instituto Multidisciplinar de Materiais Poliméricos, and Fapesp by financial support. Thank to Departamento de Engenharia de Materiais and Laboratório de Microeletrônica da Universidade de São Paulo by synthesized material, measurement equipments and installations.

## References

- [1]. M. Pope, H. Kallmann, P. Magnante, Electroluminescence in Organic Crystals, *Journal Chemistry Physics*, 38, 1963, pp. 2042-2043.
- [2]. C. G. Bangcuyo, M. E. Rampey-Vaughn, L. T. Quan, S. M. Angel, M. D. Smith, U. H. F. Bunz, Quinoline-Containing Conjugated Poly(aryleneethynylene)s: Novel Metal and H<sup>+</sup> - Responsive Material, *Macromolecules*, 2002, 35, 5, pp. 1563-1568.
- [3]. N. Miyaura, Cross-Coupling Reactions: A Practical Guide, Topics in Current Chemistry Series 219, Springer-Verlag, 2002.
- [4]. Z. H. Huang, X. T. Zeng, X. Y. Sun, E. T. Kang, Jerry Y. H. Fuh, L. Lu, Influence of plasma treatment of ITO surface on the growth and properties of hole transport layer and the device performance of OLEDs, *Organic Electronics*, 9, 2008, pp. 51–62.
- [5]. C. N. Li, C. Y. Kwong, A. B. Djurišić, P. T. Lai, P. C. Chui, W. K. Chan, S. Y. Liu, Improved performance of OLEDs with ITO surface treatments, *Thin Solid Films*, 477, 2005, pp. 57– 62.
- [6]. S. Chapman, A Theory of Upper-Atmospheric Ozone, *Memoirs of the Royal Meteorological Society*, 3, 26, 1930, pp. 103-125.
- [7]. Application Information - UV Disinfection, Perfection Preserved by the Purest of Light, Philips Netherlands, 2004, pp. 1-44.
- [8]. J. S. Kim, M. Grnstrom, R. H. Friend, N. Johansson, W. R. Salaneck, R. Daik, W. J. Feast, and F. Cacialli, Indium–tin oxide treatments for single- and double-layer polymeric light-emitting diodes: The relation between the anode physical, chemical, and morphological properties and the device performance, *Journal of Applied Physics*, 84, 12, 1998, pp. 6859–6870.
- [9]. S. K. So1, W. K. Choi, C. H. Cheng, L. M. Leung, C. F. Kwong, Surface preparation and characterization of indiumtin oxide substrates for organic electroluminescent devices, *Applied Physics A*, 68, 1999, pp. 447-450.

---

2009 Copyright ©, International Frequency Sensor Association (IFSA). All rights reserved.  
(<http://www.sensorsportal.com>)



**SENSORS WEB PORTAL** 

- MEMS
- NEMS
- NANOSENSORS
- SMART SENSORS

**All about SENSORS**  
<http://www.sensorsportal.com>

The graphic features a dark blue background with a grid pattern. On the right, a computer monitor displays the Sensors Web Portal website, which has a globe in the center and various menu items. The text is in bold, yellow and white fonts.

## Guide for Contributors

---

### Aims and Scope

*Sensors & Transducers Journal* (ISSN 1726-5479) provides an advanced forum for the science and technology of physical, chemical sensors and biosensors. It publishes state-of-the-art reviews, regular research and application specific papers, short notes, letters to Editor and sensors related books reviews as well as academic, practical and commercial information of interest to its readership. Because it is an open access, peer review international journal, papers rapidly published in *Sensors & Transducers Journal* will receive a very high publicity. The journal is published monthly as twelve issues per annual by International Frequency Association (IFSA). In addition, some special sponsored and conference issues published annually.

### Topics Covered

Contributions are invited on all aspects of research, development and application of the science and technology of sensors, transducers and sensor instrumentations. Topics include, but are not restricted to:

- Physical, chemical and biosensors;
- Digital, frequency, period, duty-cycle, time interval, PWM, pulse number output sensors and transducers;
- Theory, principles, effects, design, standardization and modeling;
- Smart sensors and systems;
- Sensor instrumentation;
- Virtual instruments;
- Sensors interfaces, buses and networks;
- Signal processing;
- Frequency (period, duty-cycle)-to-digital converters, ADC;
- Technologies and materials;
- Nanosensors;
- Microsystems;
- Applications.

### Submission of papers

Articles should be written in English. Authors are invited to submit by e-mail [editor@sensorsportal.com](mailto:editor@sensorsportal.com) 6-14 pages article (including abstract, illustrations (color or grayscale), photos and references) in both: MS Word (doc) and Acrobat (pdf) formats. Detailed preparation instructions, paper example and template of manuscript are available from the journal's webpage: <http://www.sensorsportal.com/HTML/DIGEST/Submission.htm> Authors must follow the instructions strictly when submitting their manuscripts.

### Advertising Information

Advertising orders and enquires may be sent to [sales@sensorsportal.com](mailto:sales@sensorsportal.com) Please download also our media kit: [http://www.sensorsportal.com/DOWNLOADS/Media\\_Kit\\_2008.pdf](http://www.sensorsportal.com/DOWNLOADS/Media_Kit_2008.pdf)





**e-Impact Factor 2008:  
205.767**



## **Subscription 2009**

*Sensors & Transducers Journal (ISSN 1726-5479)  
for scientists and engineers who need to be  
at cutting-edge of sensor and measuring  
technologies and their applications.*

*Keep up-to-date with the latest, most significant  
advances in all areas of sensors and transducers.*

**Take an advantage of IFSA membership  
and save **40 %** of subscription cost.**

Subscribe online:

[http://www.sensorsportal.com/HTML/DIGEST/Journal\\_Subscription\\_2009.htm](http://www.sensorsportal.com/HTML/DIGEST/Journal_Subscription_2009.htm)

e-mail: [editor@sensorsportal.com](mailto:editor@sensorsportal.com)

tel. +34 696 06 77 16

**[www.sensorsportal.com](http://www.sensorsportal.com)**