

Underwater Acoustic Communication Base on M-ary Hyperbolic Frequency Modulated-Binary Orthogonal Keying using a Passive Time Reversal Mirror Approach

En Cheng, Xiaoyang Lin, Fei Yuan*, Wei Su

Underwater Acoustic Communication and Marine Information Technology of the Ministry of Education, Xiamen University, Xiamen, 361005, P.R. China
E-mail: yuanfei@xmu.edu.cn

Received: 23 June 2014 /Accepted: 30 May 2014 /Published: 31 December 2014

Abstract: In this paper we study the HFM BOK (M-ary Hyperbolic Frequency Modulated-Binary Orthogonal Keying) modulation technology which is suitable for underwater acoustic communication. Under the guidance of the theory, we test the practicability of the system through MATLAB simulation. This system uses MFSK-MBOK cascaded technology and decreases the systematic calculated amount largely, in addition, the scheme has characteristic of constant envelope. Finally, an underwater acoustic communication system has been tested by sea experiments. The experimental results show that the system is able to achieve a robust and reliable communication under the conditions of low signal-to-noise ratio and strong multipath using passive time reversal mirror technology. Copyright © 2014 IFSA Publishing, S. L.

Keywords: Underwater acoustic communication, HFM spread spectrum, Doppler effect, Passive time reversal mirror, Multipath.

1. Introduction

Shallow water acoustic channel is a very complex space-time-frequency varying channel, the inherent characteristics, such as extensive multipath, narrow bandwidth, low frequency and high ambient noise [1]. Acoustic signals propagate underwater at a speed of 1500 m/s, the speed is much smaller than the speed of electromagnetic wave, small fluctuations of the sea waves and relative movement of receiver-transmitter both will produce much larger Doppler frequency shift than common wireless communication. Besides, both multiple reflection, refraction of sea surface, seabed and step gradient structure of acoustic velocity in ocean will cause extensive multipath in underwater acoustic channel and produce strong amplitude fluctuation, phase fluctuation [2].

Therefore, how to achieve a robust and reliable communication in complex and changeable underwater acoustic channel is a key problem in underwater acoustic communication area which is necessary to deal with.

People take a variety of methods to improve the quality of underwater communication, and spread spectrum technology is applied to underwater acoustic communication, because it has strong anti-interference ability, high concealment, and effective anti-multipath characteristic and can achieve well performance under the condition of low signal-to-noise ratio. Frequently-used underwater spread spectrum technologies include FHSS and DSSS, the former has poor performance under the condition of long distance and low signal-to-noise ratio, it needs extra channel coding technology to improve its

performance; the latter is very sensitive to Doppler frequency shift, it needs strict synchronization and complex phase real-time tracking technology [3].

Faced with the shortage of traditional spread spectrum, researcher advice applying Chirp spread spectrum (CSS) technology to underwater communication [4]. CSS is different from FHSS and DSSS, it need not add pseudo random sequence, but uses frequency linearity characteristic of Chirp signal itself. Compared to traditional spread spectrum signal, Chirp signal has high processing gain and inner anti-interference characteristics, it also makes some progress in anti-Doppler frequency shift. These characteristics make Chirp spread spectrum technology applicable in communication of underwater acoustic channel, and related studies have also begun to enter the application stage.

Hyperbolic Frequency Modulated (HFM) signal commonly used in active sonar has also begun to attract attention recent years [5], some studies show that it is more applicable than Chirp signal in solving Doppler frequency shift appeared in underwater acoustic communication. HFM signal not only has well correlation properties that Chirp signal possess, but also has Doppler invariance [6], it can improve the performance of underwater communication system in greater extent.

Based on the ideas of designing CSS, this paper chooses HFM signal as modulating signal and designs a new spread spectrum technology using a passive time reversal mirror approaching, which has anti-noise, anti-multipath and anti-Doppler frequency shift characteristics. Compared to Chirp signal, HFM signal has better Doppler tolerance.

2. HFM and PTRM Technology

2.1. HFM and Chirp Signal

Hyperbolic Frequency Modulated (HFM) signal is common sonar signal [7], it has better Doppler tolerance than Chirp signal. Especially in recent years, HFM signal becomes central issue in underwater acoustic communication, location and anti-submarine sonar areas because of its Doppler invariance. Practice has proved that transmitting or receiving HFM signal on moving platform, it has better detection capability than other signals [8].

The Frequency Modulated law of HFM signal is a hyperbolic function, supposed f_1 as start frequency, f_2 as end frequency, T as the range of time. We call signal with $f_1 < f_2$ up-HFM and those with $f_1 > f_2$ down-HFM. A HFM signal can be written as

$$HFM(t) = \cos \left[2\pi \frac{\ln(kt + 1/f_1)}{k} \right] \quad 0 < t < T, \quad (1)$$

$$\frac{1}{f_i(t)} = kt + \frac{1}{f_1} = \left(\frac{1}{f_2} - \frac{1}{f_1} \right) \frac{t}{T} + \frac{1}{f_1}, \quad (2)$$

The instantaneous frequency changes with time t in the form of hyperbolic in the range of $[f_1, f_2]$.

Fig. 1 shows the time domain waveform of HFM and Chirp signal which frequency start at 20 kHz and end with 30 kHz. Fig. 2 shows the time-frequency relationship of HFM and Chirp, the upper figure is Chirp and another is HFM. And Frequency spectrum of them is shown in Fig. 3.

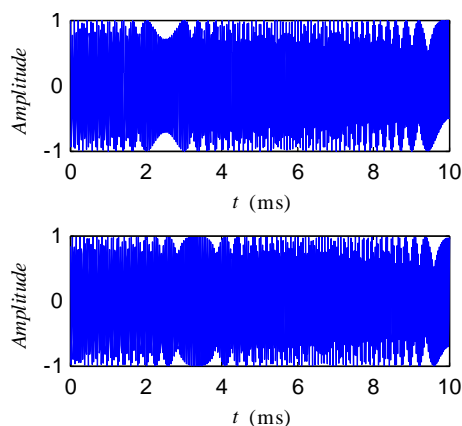

Fig. 1. Time domain waveform of HFM and Chirp.

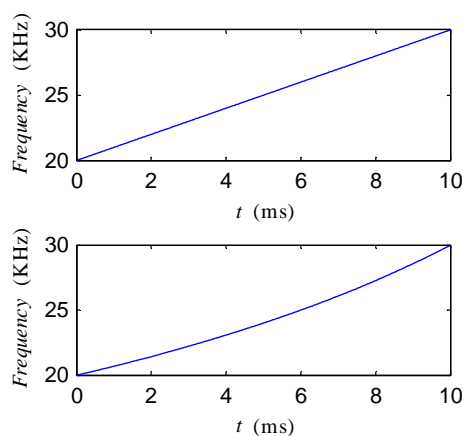

Fig. 2. Time-frequency relationship of HFM and Chirp.

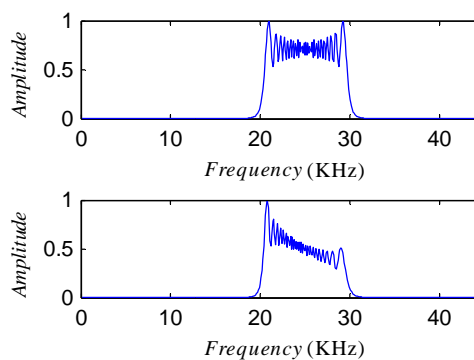

Fig. 3. Frequency spectrum of Chirp and HFM.

2.2. Pulse Compression Characteristic

HFM signal has similar pulse compression characteristic as Chirp signal, as shown in Fig. 3. Just as Chirp signal's pulse compression characteristic, the main lobe width of the output of HFM signal in matched filter is $2/B$, the main lobe height is \sqrt{BT} . HFM signal can replace Chirp signal to build communication system, its pulse compression characteristic is the basic condition. Besides, the HFM signal compared to the chirp signal has the anti-noise, and the anti-multipath characteristics and better Doppler tolerance.

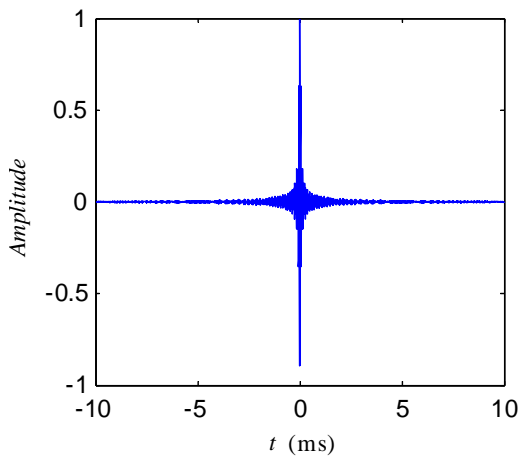

Fig. 4. Output of HFM self-correlation function.

2.3. Doppler Invariance

We assume that HFM signal occurs Doppler frequency shift during transmission. Similarly, supposing that the relative speed of receiver is v , acoustic speed is c , then the Doppler factor is $\Delta = 1 + v/c$. The instantaneous frequency of HFM signal becomes

$$f_r(t) = \frac{1}{2\pi} \frac{d\varphi_r(t)}{dt} = \frac{\Delta}{k\Delta t + 1/f_1}, \quad (3)$$

where the phase is

$$\varphi_r(t) = 2\pi \frac{\ln(k\Delta t + 1/f_1)}{k}, \quad (4)$$

Set time delay as

$$\Delta t = -\frac{\Delta}{f_1 \times k \times \Delta}, \quad (5)$$

From formula (3), we can get

$$f_r(t - \Delta t) = f_i(t), \quad (6)$$

The above states that after occurring frequency shift, HFM signal exists a time delay Δt which makes signals after occurring frequency shift matched with original signals, this is Doppler invariance of HFM signal.

2.4. PTRM Technology

Passive time reversal mirror is implemented numerically at the receiver using the measured channel response which requires a channel probe transmission followed by the information-bearing signal [9], as shown in Fig. 5. And the passive time reversal technology can depress the multipath effect on MFSK-MBOK system and enhance the robustness.

3. MFSK-MBOK Communication System Architecture

The main idea of MFSK-MBOK is combining modulation and demodulation method with multiple BOK demodulation. Receiver used MFSK to select different frequency bands. Compared with MFSK-MCrSK (Multiple frequency shift keying-multiple chirp-rate shift keying), MFSK-MBOK used FFT and matched filter to demodulation. And the limitation of MFSK-MCrSK system is that the structure of demodulation is quite complicated and the computation increases rapidly along with increasing the value of M.

The following is the example of 4FSK-4BOK modulation and demodulation system, the block diagram of the system is shown in Fig. 6, and the upper part of the block diagram is the sender. Before modulated, the original data is been serial/parallel processed, and then modulation has the parallel data to HFM waveform. After that, the modulated data is transmitted into underwater acoustic channel through Hydrophone. The receiver will judge which the frequency band the data occupy according frequency spectrum after FFT transform. And then judgment block will restore the bits according to the frequency spectrum energy.

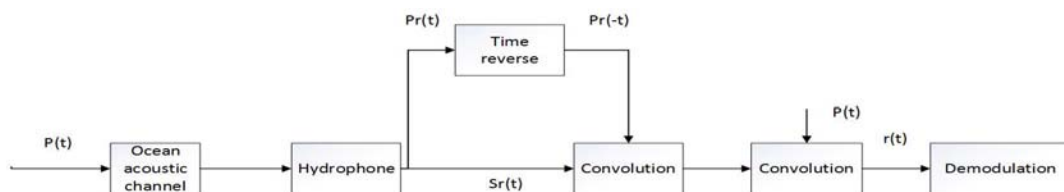

Fig. 5. Block diagram of passive time reversal mirror.

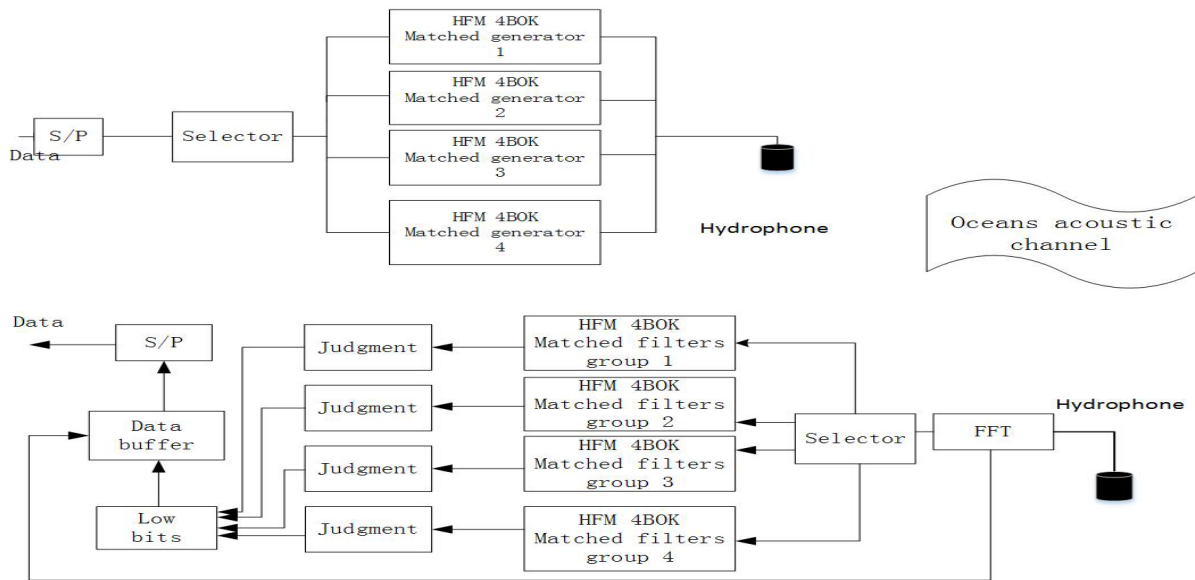

Fig. 6. Block diagram of MFSK-MBOK system.

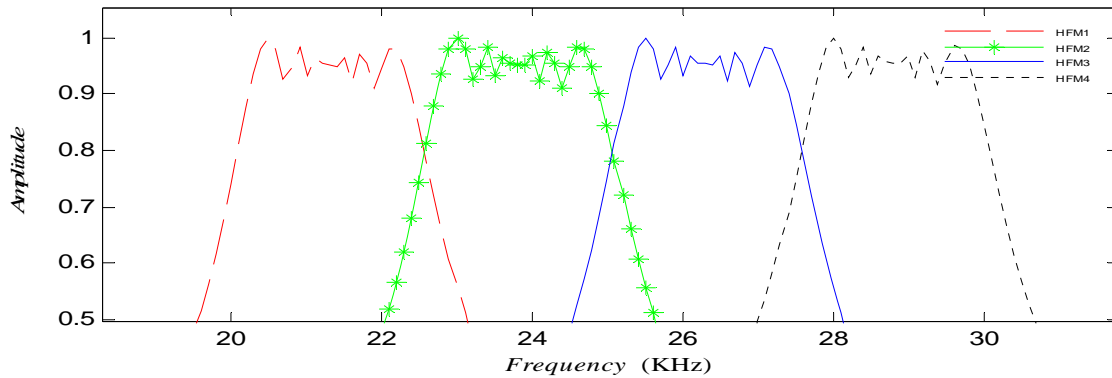

Fig. 7. HFM groups and their frequency spectrum.

We supposed that the bandwidth of the communication system range from 10 kHz to 20 kHz, and the bandwidth will be divided into four sub-bands of MFSK (10-12.5 kHz; 12.5-15 kHz; 15-17.5 kHz, 17.5-20 kHz). And each sub-band will be modulated in HFM-4BOK. And the symbol time is 10 ms, and each symbol carries 4 bits information, so the transmission rate of the system is 400 bps.

As the scheme we proposed has in common with MFSK, receiver can judge which sub-band the receive data located by using FFT processing similar to MFSK. Based on the location of sub-band, receiver can demodulate the high bits of the symbol. Next, we use matched filters group to processing the receive data in order to get the low bits. Fig. 7 shows the FFT domain of four sub-band HFM signals.

High bits of symbol determine which matched filters group is selected. And each matched filters group is equivalent to the demodulation block of single carrier HFM-4BOK that contains four parallel match filters. We can demodulate low bits information by judging the position of correlation peak.

3.1. Multipath Effect on MFSK-MBOK System

As the multipath effect means a time delay and maybe phase reverse to the original signal, each symbol time receiving data compound different segment of original data. Due to the multipath, Signal to Noise Ratio of cross-correlation of receiving and local data will be decreased, so the anti-noise performance will be degraded. In order to solve this problem, Passive time reversal mirror technology is adopted and it can depress the interference and improve SNR.

4. Sea Experimental Verification

Multipath effect is the most severe impact on the communication system in the shallow water acoustic channel. So the PTRM technology will improve the system robustness.

The experiment site is shown as Fig. 8. In the figure, point A is the sender Hydrophone, and point B

is the receiver. We select the chirp signal to probe ocean acoustic channel, the result is shown in Fig. 9.



Fig. 8. Ocean experiment site.

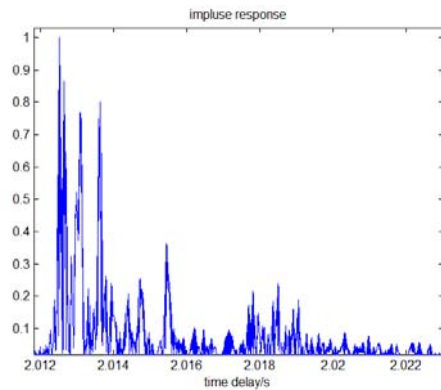

Fig. 9. Ocean channel impulse response.

We selected Chirp signal as probe signal, and output of cross-correlation of local Chirp and receiving signal is shown in Fig. 9. From the figure, we can see that the second path's energy is close to the main path and the delay is quite short.

Form Fig. 10 we can see that self-correlation of local HFM and receiving HFM function has be blurring as the channel has serious multipath effect, and this phenomenon may result in wrong judgment. As shown in Fig.11, the PTRM technology can depress the multipath effect on the cross-correlation and improve the SNR, so the PTRM technology can enhance the robust and anti-noise performance.

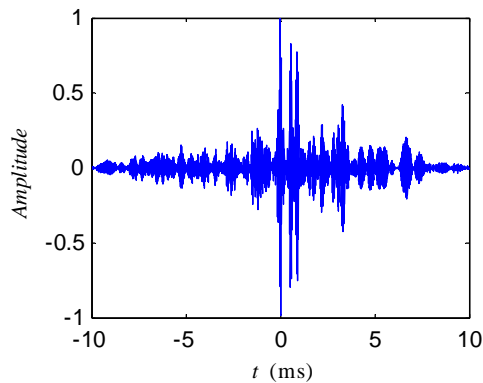

Fig. 10. Cross-correlation of receiving and HFM signal affected by multipath phenomenon.

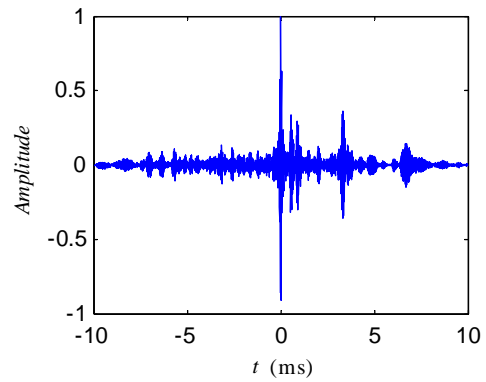

Fig. 11. Cross-correlation after PTRM processing.

Original photo is shown in Fig. 12. Fig. 13, Fig. 14 and Fig. 15 respectively show the receiving situation that SNR=-5 dB, -10 dB and -15 dB .

So the experiment can verify anti-multipath feature of the HFM system.



Fig. 12. Original photo.



Fig. 13. SNR=-5dB, BER=0.1 %.



Fig. 14. SNR=-10dB, BER=2.4 %.

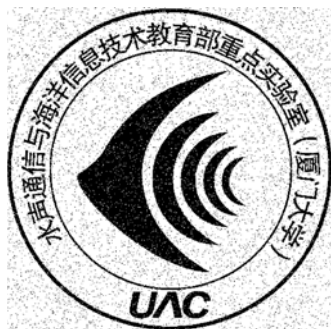

Fig. 15. SNR=-15dB, BER=5.3 %.

5. Conclusion

In this paper we propose the HFM BOK underwater acoustic communication. The scheme have characteristic of constant envelope. The sea tests results show that the system is able to achieve a robust and reliable communication under the conditions of low signal-to-noise ratio and strong multipath combining with passive time reversal mirror technology.

In the future, in order to increase the data rate, we plan to combine the phase modulation. In next we will concentrate on catching synchronous signal and make the system apply to a more obvious Doppler environment.

Acknowledgements

This work was supported by the Fundamental Research Funds for the Central Universities under Grant (2011121050, 2013121023), the National Natural Science Foundation of China (61001142, 61071150) and the Science Technology Project of Xiamen Government (3502z20123011).

References

- [1]. Mandar Chitre, Shiraz Shahabudeen, and Milica Stojanovic, Underwater acoustic communications and networking: Recent advances and future challenges, *Marine Technology Society Journal*, Vol. 42, Issue 1, 2008, pp. 103-116.
- [2]. Josko A. Catipovic, Performance limitations in underwater acoustic telemetry, *IEEE Journal of Oceanic Engineering*, Vol. 15, Issue 3, 1990, pp. 205-216.
- [3]. Gerard Loubet, Vittorio Capellano, and Richard Filipiak, Underwater spread-spectrum communications, in *Proceedings of the MTS/IEEE Conference OCEANS'97*, Vol. 1, 1997.
- [4]. Paul Hursky, et al, Point-to-point underwater acoustic communications using spread-spectrum passive phase conjugation, *The Journal of the Acoustical Society of America*, Vol. 120, Issue 1, 2006, pp. 247-257.
- [5]. Valerie Carmillet, Pierre-Olivier Amblard, and Genevieve Jourdain, Detection of phase-or frequency-modulated signals in reverberation noise, *The Journal of the Acoustical Society of America*, Vol. 105, Issue 6, 1999, pp. 3375-3389.
- [6]. J. Yang, and T. K. Sarkar, Doppler-invariant property of hyperbolic frequency modulated waveforms, *Microwave and Optical Technology Letters*, Vol. 48, Issue 6, 2006, pp. 1174-1179.
- [7]. James A. Simmons, and Roger A. Stein, Acoustic imaging in bat sonar: echolocation signals and the evolution of echolocation, *Journal of Comparative Physiology*, Vol. 135, Issue 1, 1980, pp. 61-84.
- [8]. J. P. Heritage, et al, Spectral windowing of frequency-modulated optical pulses in a grating compressor, *Applied Physics Letters*, Vol. 47, Issue 2, 1985, pp. 87-89.
- [9]. Hee C. Song, et al, Spatial diversity in passive time reversal communications, *The Journal of the Acoustical Society of America*, Vol. 120, Issue 4, 2006, pp. 2067-2076.

2014 Copyright ©, International Frequency Sensor Association (IFSA) Publishing, S. L. All rights reserved.
(<http://www.sensorsportal.com>)

Promoted by IFSA

Status of the CMOS Image Sensors Industry Report up to 2017

The report describes in detail each application in terms of market size, competitive analysis, technical requirements, technology trends and business drivers.

Order online:

http://www.sensorsportal.com/HTML/CMOS_Image_Sensors.htm