

SENSORS & TRANSDUCERS

ISSN 1726-5479

vol. 19
Special

2/13

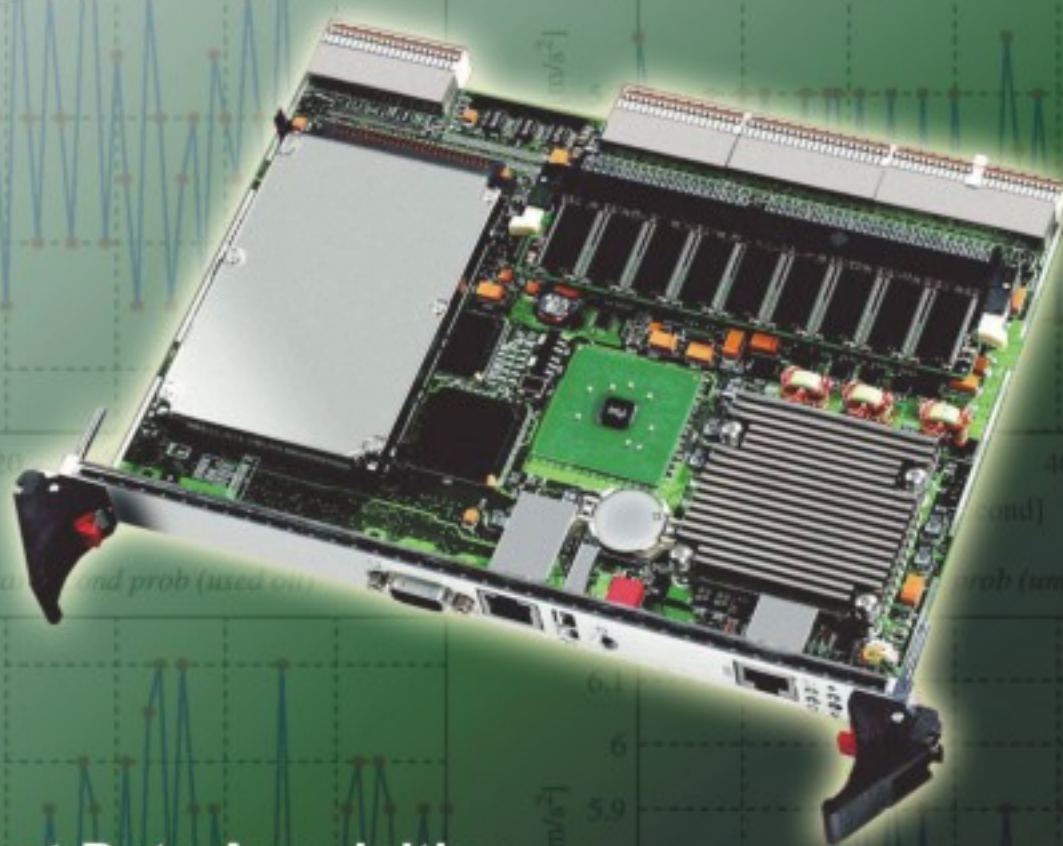

**Intelligent Data Acquisition
and Information Process Technologies
and Their Applications. Part II**

Copyright © 2013 IFSA Publishing. All rights reserved.

This journal and the individual contributions in it are protected under copyright by IFSA Publishing, and the following terms and conditions apply to their use:

Photocopying: Single photocopies of single articles may be made for personal use as allowed by national copyright laws. Permission of the Publisher and payment of a fee is required for all other photocopying, including multiple or systematic copyright, copyright for advertising or promotional purposes, resale, and all forms of document delivery.

Derivative Works: Subscribers may reproduce tables of contents or prepare list of articles including abstract for internal circulation within their institutions. Permission of the Publisher is required for resale or distribution outside the institution.

Permission of the Publisher is required for all other derivative works, including compilations and translations.

Authors' copies of Sensors & Transducers journal and articles published in it are for personal use only.

Address permissions requests to: IFSA Publisher by e-mail: editor@sensorsportal.com

Notice: No responsibility is assumed by the Publisher for any injury and/or damage to persons or property as a matter of products liability, negligence or otherwise, or from any use or operation of any methods, products, instructions or ideas contained in the material herein.

Printed in the USA.



Sensors & Transducers

Volume 19, Special Issue
February 2013

www.sensorsportal.com

ISSN 1726-5479

Editors-in-Chief: professor Sergey Y. Yurish,
Tel.: +34 696067716, e-mail: editor@sensorsportal.com

Editors for Western Europe

Meijer, Gerard C.M., Delft Univ. of Technology, The Netherlands
Ferrari, Vittorio, Università di Brescia, Italy

Editor for Eastern Europe

Sachenko, Anatoly, Ternopil National Economic University, Ukraine

Editors for North America

Katz, Evgeny, Clarkson University, USA
Datskos, Panos G., Oak Ridge National Laboratory, USA
Fabien, J. Josse, Marquette University, USA

Editor South America

Costa-Felix, Rodrigo, Inmetro, Brazil

Editors for Asia

Ohyama, Shinji, Tokyo Institute of Technology, Japan
Zhengbing, Hu, Huazhong Univ. of Science and Technol., China

Editor for Asia-Pacific

Mukhopadhyay, Subhas, Massey University, New Zealand

Editor for Africa

Maki K.Habib, American University in Cairo, Egypt

Editorial Board

Abdul Rahim, Ruzairi, Universiti Teknologi, Malaysia
Abramchuk, George, Measur. Tech. & Advanced Applications, Canada
Ascoli, Giorgio, George Mason University, USA
Atalay, Selcuk, Inonu University, Turkey
Atghiaee, Ahmad, University of Tehran, Iran
Augutis, Vygtantas, Kaunas University of Technology, Lithuania
Ayesh, Aladdin, De Montfort University, UK
Baliga, Shankar, B., General Monitors, USA
Basu, Sukumar, Jadavpur University, India
Bouvet, Marcel, University of Burgundy, France
Campanella, Luigi, University La Sapienza, Italy
Carvalho, Vitor, Minho University, Portugal
Changhai, Ru, Harbin Engineering University, China
Chen, Wei, Hefei University of Technology, China
Cheng-Ta, Chiang, National Chia-Yi University, Taiwan
Chung, Wen-Yaw, Chung Yuan Christian University, Taiwan
Cortes, Camilo A., Universidad Nacional de Colombia, Colombia
D'Amico, Arnaldo, Università di Tor Vergata, Italy
De Stefano, Luca, Institute for Microelectronics and Microsystem, Italy
Ding, Jianning, Changzhou University, China
Djordjevic, Alexander, City University of Hong Kong, Hong Kong
Donato, Nicola, University of Messina, Italy
Dong, Feng, Tianjin University, China
Erkmen, Aydan M., Middle East Technical University, Turkey
Gaura, Elena, Coventry University, UK
Gole, James, Georgia Institute of Technology, USA
Gong, Hao, National University of Singapore, Singapore
Gonzalez de la Rosa, Juan Jose, University of Cadiz, Spain
Guillet, Bruno, University of Caen, France
Hadjiloucas, Sillas, The University of Reading, UK
Hui, David, University of New Orleans, USA
Jaffrezic-Renault, Nicole, Claude Bernard University Lyon 1, France
Jamil, Mohammad, Qatar University, Qatar
Kaniusas, Eugenijus, Vienna University of Technology, Austria
Kim, Min Young, Kyungpook National University, Korea
Kumar, Arun, University of Delaware, USA
Lay-Ekuakille, Aime, University of Lecce, Italy
Lin, Paul, Cleveland State University, USA
Liu, Aihua, Chinese Academy of Sciences, China

Mansor, Muhammad Naufal, University Malaysia Perlis, Malaysia
Marquez, Alfredo, Centro de Investigacion en Materiales Avanzados, Mexico
Mishra, Vivekanand, National Institute of Technology, India
Moghavvemi, Mahmoud, University of Malaya, Malaysia
Morello, Rosario, University "Mediterranea" of Reggio Calabria, Italy
Mulla, Imtiaz Sirajuddin, National Chemical Laboratory, Pune, India
Nabok, Aleksey, Sheffield Hallam University, UK
Neshkova, Milka, Bulgarian Academy of Sciences, Bulgaria
Passaro, Vittorio M. N., Politecnico di Bari, Italy
Penza, Michele, ENEA, Italy
Pereira, Jose Miguel, Instituto Politecnico de Seteбал, Portugal
Pogacnik, Lea, University of Ljubljana, Slovenia
Pullini, Daniele, Centro Ricerche FIAT, Italy
Reig, Candid, University of Valencia, Spain
Restivo, Maria Teresa, University of Porto, Portugal
Rodríguez Martínez, Angel, Universidad Politécника de Cataluña, Spain
Sadana, Ajit, University of Mississippi, USA
Sadeghian Marnani, Hamed, TU Delft, The Netherlands
Sapozhnikova, Ksenia, D. I. Mendeleev Institute for Metrology, Russia
Singhal, Subodh Kumar, National Physical Laboratory, India
Shah, Kriyang, La Trobe University, Australia
Shi, Wendian, California Institute of Technology, USA
Shmaliy, Yuriy, Guanajuato University, Mexico
Song, Xu, An Yang Normal University, China
Srivastava, Arvind K., LightField, Corp, USA
Stefanescu, Dan Mihai, Romanian Measurement Society, Romania
Sumriddetchkajorn, Sarun, Nat. Electr. & Comp. Tech. Center, Thailand
Sun, Zhiqiang, Central South University, China
Sysoev, Victor, Saratov State Technical University, Russia
Thirunavukkarasu, I., Manipal University Karnataka, India
Vazquez, Carmen, Universidad Carlos III Madrid, Spain
Wang, Jiangping, Xian Shiyou University, China
Xue, Ning, Agiltron, Inc., USA
Yang, Dongfang, National Research Council, Canada
Yang, Shuang-Hua, Loughborough University, UK
Yaping Dan, Harvard University, USA
Zakaria, Zulkarnay, University Malaysia Perlis, Malaysia
Zhang, Weiping, Shanghai Jiao Tong University, China
Zhang, Wenming, Shanghai Jiao Tong University, China

Contents

Volume 19
Special Issue
February 2013

www.sensorsportal.com

ISSN 1726-5479

Research Articles

Study on VSI Switching Frequency Optimization of PMSM Based Servo System <i>Shi-xiong Zhang</i>	1
Application of an Improved Genetic Algorithm in Network Information Filtering <i>Min Ren, Baoya Song, Jirong Jiang</i>	7
Compression of Power Quality Data Based on Improved DCT Transform <i>Hua Ouyang, Hui Li, Mei Qian</i>	13
Mechanical Optimization Design Based on Genetic Algorithm <i>Ying Sun, Yuesheng Gu and Hegen Xiong</i>	19
Camera Pose Estimation in Dynamic Scenes with Background Tracking <i>Dong Zhang and Ping Li</i>	25
Application of Step Design Method to Realize the Synchronization of Genesisio Chaotic System <i>Yu ZhiPeng</i>	34
Short-term Probabilistic Load Forecasting with the Consideration of Human Body Amenity <i>Ning Lu</i>	39
Analysis on Rural Land Circulation Subject Interests <i>Shi Dong-mei, Xu Yue-ming, Wang Jian, Tong Lei</i>	45
A High Precision Multi-function Electronic Scale Based on PSoC3 <i>Lv Dian-ji, Peng Jian-sheng, Zhou Guo-juan, Xu Yong</i>	51
Studies on Equalization Strategy of Battery Management System for Electric Vehicle <i>Nan Jinrui, Guo Meng</i>	57
Design and Optimal Control of Parallel Robot <i>Ying Sun, Yuesheng Gu and Hegen Xiong</i>	64
Pure Surface Texture Mapping Technology and it's Application for Mirror Image <i>Wei Feng Wang, Hui Feng Yan, QinMao, Ming Liang Zhou</i>	68
Forming Flaws Analysis of Lead Screw Cold Roll-Beating Based on Stress-Strain Evolution <i>He Wangyun, Li Yan, Yang Mingshun, Wang Ming</i>	74
A Reflective Grating Microcantilever Biosensor <i>Feng Wen, Yuejin Zhao, Xiaomei Yu, Cheng Gong, Jiancheng Yang</i>	83

Authors are encouraged to submit article in MS Word (doc) and Acrobat (pdf) formats by e-mail: editor@sensorsportal.com
Please visit journal's webpage with preparation instructions: <http://www.sensorsportal.com/HTML/DIGEST/Submission.htm>

International Frequency Sensor Association (IFSA).



International Frequency Sensor Association (IFSA) Publishing

Digital Sensors and Sensor Systems: Practical Design

Sergey Y. Yurish



Formats: printable pdf (Acrobat) and print (hardcover), 419 pages

ISBN: 978-84-616-0652-8,
e-ISBN: 978-84-615-6957-1

The goal of this book is to help the practitioners achieve the best metrological and technical performances of digital sensors and sensor systems at low cost, and significantly to reduce time-to-market. It should be also useful for students, lectures and professors to provide a solid background of the novel concepts and design approach.

Book features include:

- Each of chapter can be used independently and contains its own detailed list of references
- Easy-to-repeat experiments
- Practical orientation
- Dozens examples of various complete sensors and sensor systems for physical and chemical, electrical and non-electrical values
- Detailed description of technology driven and coming alternative to the ADC a frequency (time)-to-digital conversion

Digital Sensors and Sensor Systems: Practical Design will greatly benefit undergraduate and at PhD students, engineers, scientists and researchers in both industry and academia. It is especially suited as a reference guide for practitioners, working for Original Equipment Manufacturers (OEM) electronics market (electronics/hardware), sensor industry, and using commercial-off-the-shelf components

http://sensorsportal.com/HTML/BOOKSTORE/Digital_Sensors.htm



International Frequency Sensor Association (IFSA) Publishing

NEW BOOK

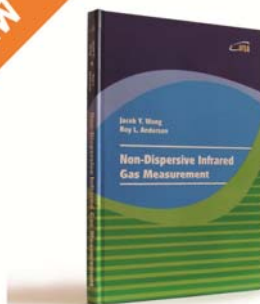

Formats: printable pdf (Acrobat) and print (hardcover), 120 pages

ISBN: 978-84-615-9732-1,
e-ISBN: 978-84-615-9512-9

Jacob Y. Wong, Roy L. Anderson

Non-Dispersive Infrared Gas Measurement

Written by experts in the field, the *Non-Dispersive Infrared Gas Measurement* begins with a brief survey of various gas measurement techniques and continues with fundamental aspects and cutting-edge progress in NDIR gas sensors in their historical development.

- It addresses various fields, including:
- Interactive and non-interactive gas sensors
- Non-dispersive infrared gas sensors' components
- Single- and Double beam designs
- Historical background and today's of NDIR gas measurements

Providing sufficient background information and details, the book *Non-Dispersive Infrared Gas Measurement* is an excellent resource for advanced level undergraduate and graduate students as well as researchers, instrumentation engineers, applied physicists, chemists, material scientists in gas, chemical, biological, and medical sensors to have a comprehensive understanding of the development of non-dispersive infrared gas sensors and the trends for the future investigation.

http://sensorsportal.com/HTML/BOOKSTORE/NDIR_Gas_Measurement.htm



The Fourth International Conference on Sensor Device Technologies and Applications

SENSORDEVICES 2013

25 - 31 August 2013 - Barcelona, Spain

Tracks: Sensor devices - Ultrasonic and Piezosensors - Photonics - Infrared - Gas Sensors - Geosensors - Sensor device technologies - Sensors signal conditioning and interfacing circuits - Medical devices and sensors applications - Sensors domain-oriented devices, technologies, and applications - Sensor-based localization and tracking technologies - Sensors and Transducers for Non-Destructive Testing

Deadline for papers: 30 March 2013

<http://www.aria.org/conferences2013/SENSORDEVICES13.html>



The Seventh International Conference on Sensor Technologies and Applications

**Deadline for papers:
30 March 2013**

SENSORCOMM 2013

25 - 31 August 2013 - Barcelona, Spain

Tracks: Architectures, protocols and algorithms of sensor networks - Energy, management and control of sensor networks - Resource allocation, services, QoS and fault tolerance in sensor networks - Performance, simulation and modelling of sensor networks - Security and monitoring of sensor networks - Sensor circuits and sensor devices - Radio issues in wireless sensor networks - Software, applications and programming of sensor networks - Data allocation and information in sensor networks - Deployments and implementations of sensor networks - Under water sensors and systems - Energy optimization in wireless sensor networks

<http://www.aria.org/conferences2013/SENSORCOMM13.html>



The Sixth International Conference on Advances in Circuits, Electronics and Micro-electronics

CENICS 2013

25 - 31 August 2013 - Barcelona, Spain

Deadline for papers: 30 March 2013

Tracks: Semiconductors and applications - Design, models and languages - Signal processing circuits - Arithmetic computational circuits - Microelectronics - Electronics technologies - Special circuits - Consumer electronics - Application-oriented electronics

<http://www.aria.org/conferences2013/CENICS13.html>



A High Precision Multi-Function Electronic Scale Based on PSoC3

¹ LV Dian-Ji, ² PENG Jian-Sheng, ¹ ZHOU Guo-Juan, ² XU Yong

¹ Department of Mechanical and Electronic, Beijing Institute of Economic Management,
Beijing 100029, China

Tel.: 0086+13683179858

² Department of Physics and electronic engineering, Hechi University,
Yizhou, Guangxi 546300, China

Tel.: 0086+13907786821

E-mail: lvdianji@biem.edu.cn, sheng120410@163.com

Received: 4 December 2012 /Accepted: 15 January 2013 /Published: 19 February 2013

Abstract: PSoC3 is adopted as the controller core of the design, and resistance strain type pressure sensor is the weighing transducer. Use by the built-in analog and digital resources and a small external function module of PSoC3, designed a new type of electronic scale with touch induction buttons and slider as the main operation interface. After the whole debugging and actual testing, realized the calibration, speech broadcast, zeros, peeling, PC processing, currency conversion, calendar, temperature and humidity detection and other capabilities. With many characteristics, such as good stability, high accuracy, the function is all ready, show intuitional and simple operation, etc. Can be used for the occasion which needs some high precision weighing, such as civil and industrial. *Copyright © 2013 IFSA.*

Keywords: Electronic scale, PSoC3, High precision, Multi-functional, Touch induction.

1. Introduction

Along with the electronic technology and automation measurement technology of development, in China, the traditional weighing system in the aspects of accuracy ratio of function has been difficult to satisfy people's needs, especially in intelligent portable tiny the measurement of quality, etc; And the developed countries in the electronic weighing, no matter from the technical level variety and size and so on to a higher level, especially in accuracy long-term stability and reliability have great advantage in recent years, with the development of integrated circuit technology and new chip system appear, for

development of high quality weighing system provides favorable conditions, especially the programmable chip system PSoC3 the advent of [1-3].

Review at home and abroad, electronic said was in high precision multi-functional intelligent high stability and simple operation in the direction of the high speed development of the design according to the development of science and technology and the demand of the market, in recent years the development direction of the electronic scale as the goal, make full use of the PSoC3 chip analog to digital resources, USES the ratio type method of measurement section translation calibration/calculation weighing value method and the improved traditional weighing value

shows that processing method, design a kind of maximum range is 25 kg, minimum quantity of feeling for 1 g, precision for 1/25000 of the high precision multi-functional electronic says.

2. System Structure and Principle

Electronic scale is equipped with electronic weighing device of weighing apparatus, mainly by the weighing sensor bearing device (commonly known as scale frame) weighing instrument 3 parts [4], its

working principle is to function in the bearing device on the quality or force size, through the weighing sensor into the electrical signal proportional to, and to analog or digital quantity in the form of weighing instrument display.

The system is composed of power module resistance strain type pressure sensor Nokia5110 liquid crystal display module DHT11 temperature and humidity acquisition module WT588D voice module and PSoC3 control module system block diagram as shown in Fig. 1.

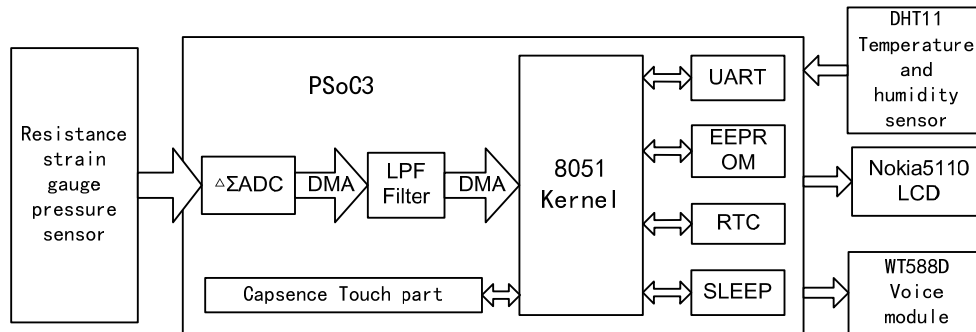

Fig. 1. System structure.

The working principle of the system are as follows: resistance strain type pressure sensor acquisition for pressure change and the resulting voltage signal, through the PSoC3 built-in A/D converter will analog signal is converted to A digital signal, the digital signal via DMA into low pass filter, processed digital signal then through DMA into kernel processing, the kernel do corresponding treatment, get the current the weight of the body data, and through the LCD display, in addition, PSoC3 kernel also is responsible for Capacitance UART RTC EEPROM SLEEP components such as [5-6] and DHT11 temperature and humidity sensor and WT588D voice module processing.

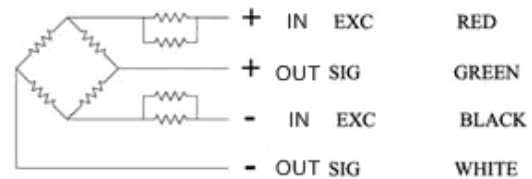

Fig. 2. Resistance strain gauge pressure sensor schematic.

3. The System Hardware Design

3.1. Resistance Strain Type Pressure Sensor

Resistance strain type pressure sensor is mainly composed of elastomer resistance strain gauge cables, etc, the internal circuit using huygens bridge, when elastic deformation under load, the resistance strain gauge is tensile or compressive strain slice deformation, its value will change (increase or decrease), so that the bridge is out of balance, produce the corresponding differential signal, for the next circuit measurement and processing of the system the resistance strain type pressure sensor principle diagram and connection diagram are shown in Fig. 2 and 3 respectively.

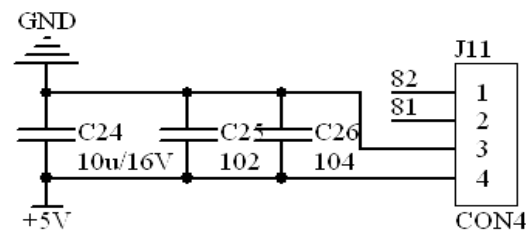

Fig. 3. Resistance strain gauge pressure sensor connection.

3.2. PSoC3 Internal Resource Allocation

The PSoC3 CY8C38 series chip has many device integration, such already to avoid the complex connection, and reduce the use of peripheral equipments and reduce the design cost, improve the reliability and accuracy [5] - [6]. This system PSoC3 specify the internal resources include a 18 of the Delta Sigma ADC two DMA a low pass filter, 10 touch induction key, 1 group touch induction slider a EEPROM component a real-time clock RTC

component one UART serial communication module 1 SLEEP component 1 Nokia5110 LCD liquid crystal display modules and several corresponding external module communication pin, and the specific configuration shown as shown in Fig. 4.

3.3. Touch the Keyboard and Strip Design

PSoC3 touch induction adopted a Delta - Sigma modulator (CSD) capacitive sensing method [7] PSoC3 use the touch of induction make a design personnel in a short span of a few minutes can achieve touch induction keys and strip function this design by 10 capacitance type touch key constitute a touch the keyboard and five capacitance type touch key constitute a touch induction slider, use 10 resolution 24 MHZ acquisition rate single channel high speed scan Capsense mode this design touch induction keyboard principle diagram as shown in Fig. 5.

4. System Optimization Design

4.1. System Measuring Method

In order to achieve the best performance, the design USES the ratio type measuring method (bridge DC excitation source and PSoC3 built-in ADC reference voltage source to use the same reference source) ratio type measuring method of the output voltage with both of the bridge excitation voltage proportional and ADC reference voltage source in proportion, so even if the actual bridge excitation voltage change also won't affect the measurement accuracy this ratio type measuring eliminates the excitation source of temperature drift and extremely low frequency noise on the influence of output accuracy for filtering ADC input from weighing sensor noise, this design in weighing sensor power supply end with a decoupling filtering capacity.

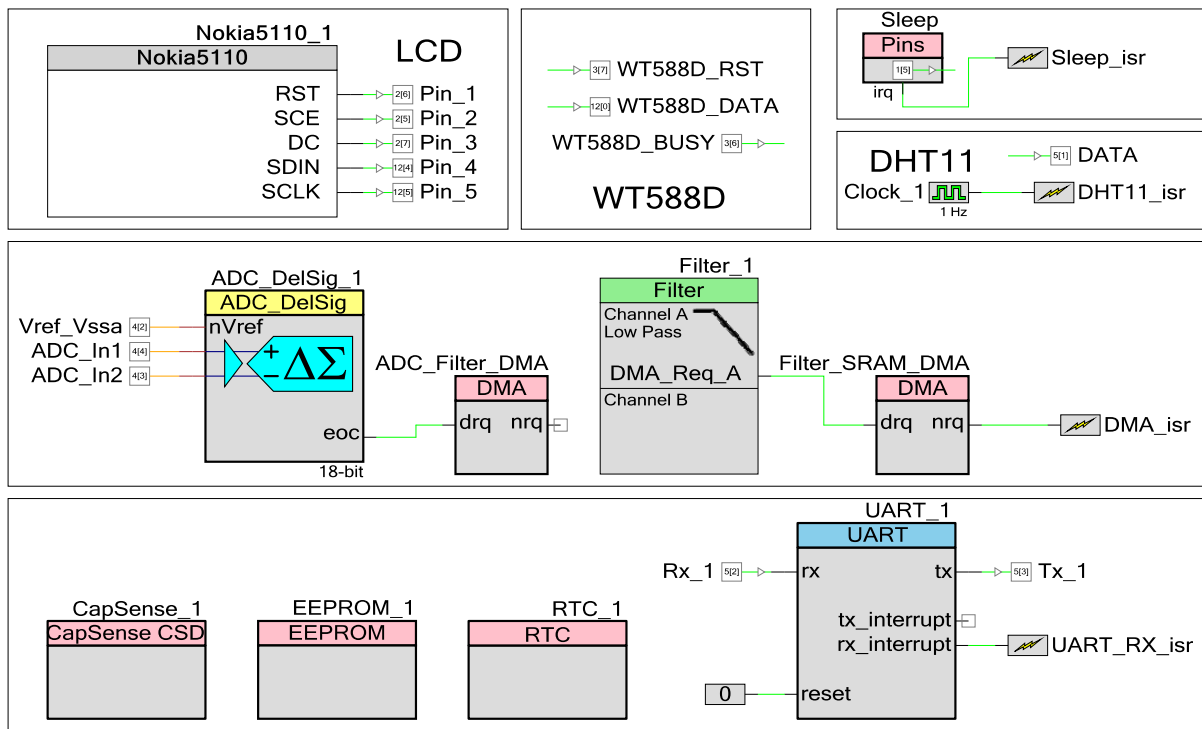

Fig. 4. PSoC3 internal resource allocation.

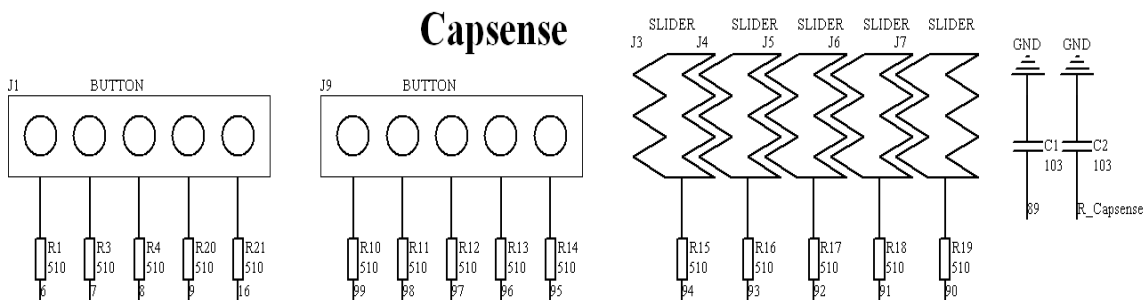

Fig. 5. Touch-sensitive keyboard schematic.

4.2. Nonlinear Compensation Method

Due to the impact of the factors such as temperature and the ADC linearity is not ideal, make weighing linearity change so this design using piecewise linear interpolation method, using piecewise calibration weighing value and piecewise calculation weighing value, its greatly reduced weighing value of relative error [2, 8].

In addition, the system also used two calibration methods: piecewise linear calibration and zero calibration piecewise linear calibration use calibration equipment such as weight on the corresponding calibration value of linear block calibration, draw calibration matrix, and finally figure out each linear segment of calibration slope, in order to calculating weighing value; Zero calibration is opposition zero drift, to correction system zero.

4.3. Weighing Value Display Method

Although the use PSoC3 built-in low pass filter has achieved the good filtering effect, but weighing value display or is not so stable, so this system combines the traditional electronic scale processing methods, the use of the measured value transformation weighing value, and then take a certain amount of data mean value, set a number of average, when the frequency arrived, for these mean to average, get a relatively stable weighing value if weighing value did not change, would say no change; If weighing value change but not exceed 1/2 a minimum amount of sense, still think weighing value did not change; If beyond, should carry out a series of comparison to determine whether or not a new weight to join [2, 8, 9] the actual test shows this method can effectively solve the weighing value shows that unstable problem says (see Fig. 6).

5. System Software Design

System programming design is in the cypress semiconductor company PSoC Creator integrated development environment of PSoC Creator integrated development environment for each module the application to provide a lot of API and interrupt service routine ISR, when writing application just call the function, can realize the function of the module.

5.1. The Main Menu Programming

This system work is divided into initial interface mode measurement model calibration mode setting mode and other mode, according to different key value into different patterns, the realization of different function this system main program flow chart shown as shown in Fig. 7.

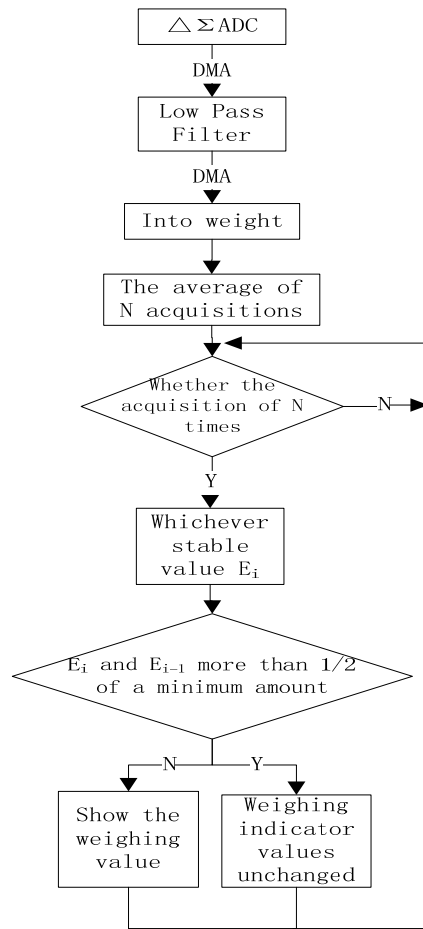

Fig. 6. Weighing value of show flow chart.

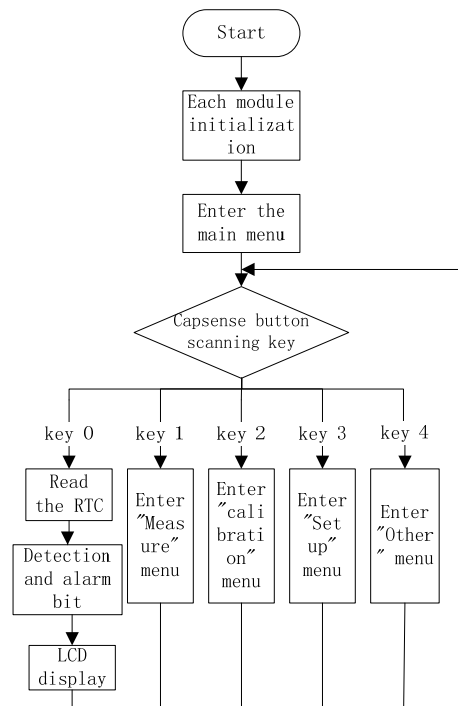

Fig. 7. Main program flow chart.

5.2. Weighing Measuring Program Design

Weighing measuring menu is mainly complete weighing measuring and display voice broadcast unit price change and set value, and other functions, and the main menu programming ideas similar, its flow chart shown as shown in Fig. 8.

5.3. PC Program Design

Epistatic machine programming by VC write complete, the use of parameters for the baud rate for 9600 black and white even parity bit 8 bits of data a one stop bits serial interface for communication, is based on the dialog MFC AppWizard applications,

realize the PC and PSoC3 weighing measuring communication between [10] epistatic machine interface as shown in Fig. 9.

6. System Test and Analysis

This system USES a set of standard weight (type: 1 g 2 g 2 g 5 g 10 g 10 g 20 g 50 g 100 g 100 g 200 g 500 g) after calibration and test, test results as is shown in Table 1.

Through the above, it is known that this system test results are reasonable, error basic for 1 g, this system accuracy is higher, comply with the design requirements.

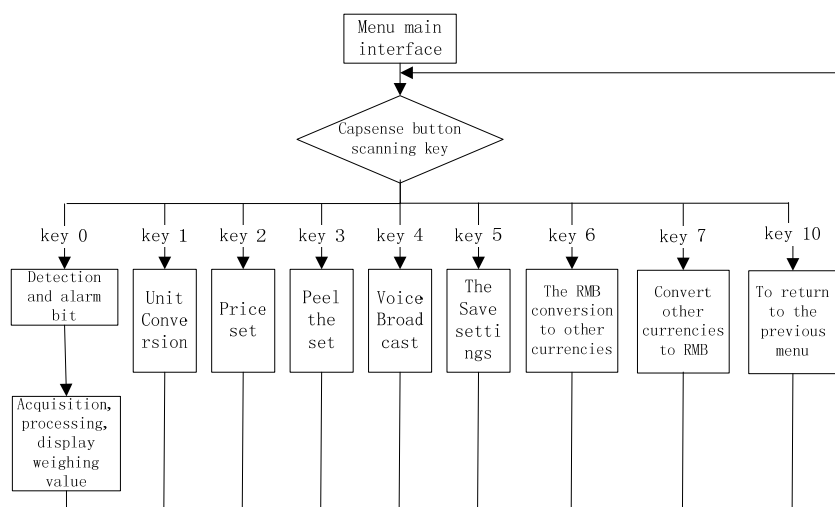

Fig. 8. Weighing the program flow chart.

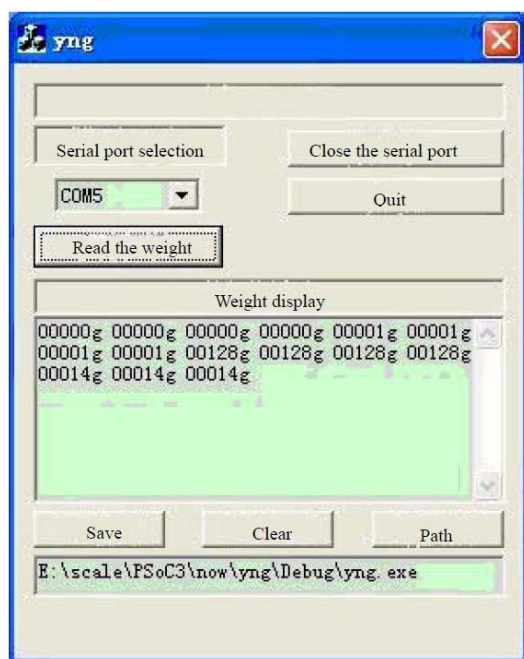

Fig. 9. Electronic PC interface.

Table 1. Test results.

Test weight/g	Test 1	Test 2	Test 3
1	1	1	1
2	2	2	2
5	5	5	5
10	10	10	10
20	20	19	20
50	50	49	50
100	100	99	99
200	199	199	200
500	499	499	499
1000	999	999	1000

7. Conclusions

This paper introduces PSoC3 based on the high precision multi-functional electronic says design, make full use of the internal resources PSoC3 adoption of good system optimization design method and use efficient program design, realized the high

precision measurement of electronic balance functions through the physical test, the design has reached the expected related technical indicator; Compared with the traditional electronic says system, this design further highlights the peripheral hardware circuit simple high accuracy complete function convenient operation short development cycle and stable performance, etc, and have higher practical value and broad application prospect in the market.

Acknowledgements

The work presented in this paper was supported by the Guangxi educational class A project (2010 JGA065), Guangxi education science 1025 planning project (2011C0104), China password learn to aid projects (CACR2012E23).

References

- [1]. Li Kang, Zuo Jinping, Jin Sanmei, Design of High-precision Electronic Balance Based on AVR MCU, *J. Electronic Technology*, 25, 7, 2011, p. 29.
- [2]. WANG De Qing, HU Xiao Yi, JIA Hong, et al, The design and realization of high precision electronic scale based on SPCE061A, *J Application of Electronic Technique*, 31, 5, 2008, pp. 83-86.
- [3]. Wang Xian An, Wang Xian Yu, A pocket scale design, *J. Light Industry Machinery*, 25, 2, 2007, pp. 110-113.
- [4]. ZHAO Guangping, SUN Wenping, SUN Jianjun, Present Condition and Development of Electronics Weighs Technique, *J Instrument Technology and Sensor*, 21, 7, 2007, pp. 76-77.
- [5]. Cypress, PSoC®5:CY8C55 Family Datasheet [EB/OL], (2011-4-10), <http://www.cypress.com/?rID=37581>.
- [6]. Cypress, PSoC®Creator™ Component Data Sheet [EB/OL, 2011(2011-4-15), <http://www.cypress.com/?app=search&searchType=keyword&keyword=PSoC5+Component>.
- [7]. PENG Jiansheng, LI Xing, QIN Zhiqiang, Design of Portable Multi-channel γ Spectrometer Based on PSoC3, *J. Nuclear Electronics & Detection Technology*, 7, 2012, pp. 829-833.
- [8]. Wang Wei Qiang, Pan Gang, Signal processing and self-adaptive compensation design of dynamic weighing system, *J. Transducer and Microsystem Technology*, 7, 2010, pp. 69-71.
- [9]. CHEN Liang-Zhu, TENG Zhao-Sheng, YANG Min, Design of weighing unit of electronic balance based on DSP, *J Sensor and Micro Systems*, 2, 2011, pp. 68-70.
- [10]. Gong Jian Wei, Xiong Guang Ming, VisualC++ / TurboC serial communication programming practice (second edition), *Publishing House of Electronics Industry*, Beijing, 2009.

2013 Copyright ©, International Frequency Sensor Association (IFSA). All rights reserved.
(<http://www.sensorsportal.com>)

International Frequency Sensor Association (IFSA) Publishing

Maria Teresa Restivo, Fernando Gomes de Almeida, Maria de Fátima Chouzal

Strain Measurement

Measurement of Physical and Chemical Quantities Series

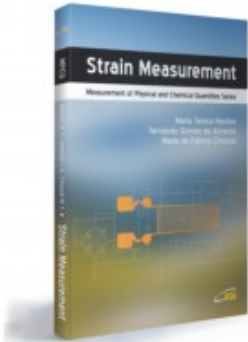

Formats: printable pdf (Acrobat) and print (hardcover), 106 pages
ISBN: 978-84-616-0067-0,
e-ISBN: 978-84-615-9897-7

"Strain Measurement" deals with measurement of stresses and strains in mechanical and structural components. This topic is related to such diverse disciplines as physical and mechanical sciences, engineering (mechanical, aeronautical, civil, automotive, nuclear, etc.), materials, electronics, medicine and biology, and uses experimental methodologies to test and evaluate the behaviour and performance of all kinds of materials, structures and mechanical systems.

The material covered includes:

- Introduction to the elementary concepts of stress and strain state of a body;
- Experimental extensometry measurement techniques;
- Basic instrumentation theory and techniques associated with the use of strain gauges;
- Optical fibre based extensometry;
- Uncertainty estimation on the measurement of mechanical stress;
- Supplemented multimedia components such as animations, simulations and video clips.

The different subjects exposed in this book are presented in a very simple and easy sequence, which makes it most adequate for engineering students, technicians and professionals, as well as for other users interested in mechanical measurements and related instrumentation.

http://sensorsportal.com/HTML/BOOKSTORE/Strain_Measurement.htm

Aims and Scope

Sensors & Transducers is a peer reviewed international, interdisciplinary journal that provides an advanced forum for the science and technology of physical, chemical sensors and biosensors. It publishes original research articles, timely state-of-the-art reviews and application specific articles with the following devices areas:

- Physical, chemical and biosensors;
- Digital, frequency, period, duty-cycle, time interval, PWM, pulse number output sensors and transducers;
- Theory, principles, effects, design, standardization and modeling;
- Smart sensors and systems;
- Sensor instrumentation;
- Virtual instruments;
- Sensors interfaces, buses and networks;
- Signal processing and interfacing;
- Frequency (period, duty-cycle)-to-code converters, ADC;
- Technologies and materials;
- Nanosensors;
- Microsystems;
- Applications.

Further information on this journal is available from the Publisher's web site:
<http://www.sensorsportal.com/HTML/DIGEST/Submission.htm>

Subscriptions

An annual subscription includes 12 regular issues and some special issues. Annual subscription rates for 2013 are the following:

Electronic version (in printable pdf format): 400.00 EUR

Printed with b/w illustrations: 640.00 EUR

Printed full color version: 760.00 EUR

40 % discount is available for IFSA Members.

Prices include shipping costs by mail. Further information about subscription is available through IFSA Publishing's web site: http://www.sensorsportal.com/HTML/DIGEST/Journal_Subscription.htm

Advertising Information

If you are interested in advertising or other commercial opportunities please e-mail sales@sensorsportal.com and your enquiry will be passed to the correct person who will respond to you within 24 hours. Please download also our Media Planner 2013: http://www.sensorsportal.com/DOWNLOADS/Media_Planner_2013.pdf

Books for Review

Publications should be sent to the IFSA Publishing Office: Ronda de Ramon Otero Pedrayo, 42C, 1-5, 08860, Castelldefels, Barcelona, Spain.

Abstracting Services

This journal is cited, indexed and abstracted by Chemical Abstracts, EBSCO Publishing, IndexCopernicus Journals Master List, ProQuest Science Journals, CAS Source Index (CASSI), Ulrich's Periodicals Directory, Scirus, Google Scholar, etc. Since 2011 *Sensors & Transducers* journal is covered and indexed (including a Scopus, Embase, Engineering Village and Reaxys) in *Elsevier* products.

Instructions for Authors

Please visit the journal web page <http://www.sensorsportal.com/HTML/DIGEST/Submission.htm> Authors must follow the instructions very carefully when submitting their manuscripts. Manuscript must be send electronically in both: MS Word 2003 for Windows (doc) and Acrobat (pdf) formats by e-mail: editor@sensorsportal.com

Sergey Y. Yurish
Editor

Modern Sensors, Transducers and Sensor Networks

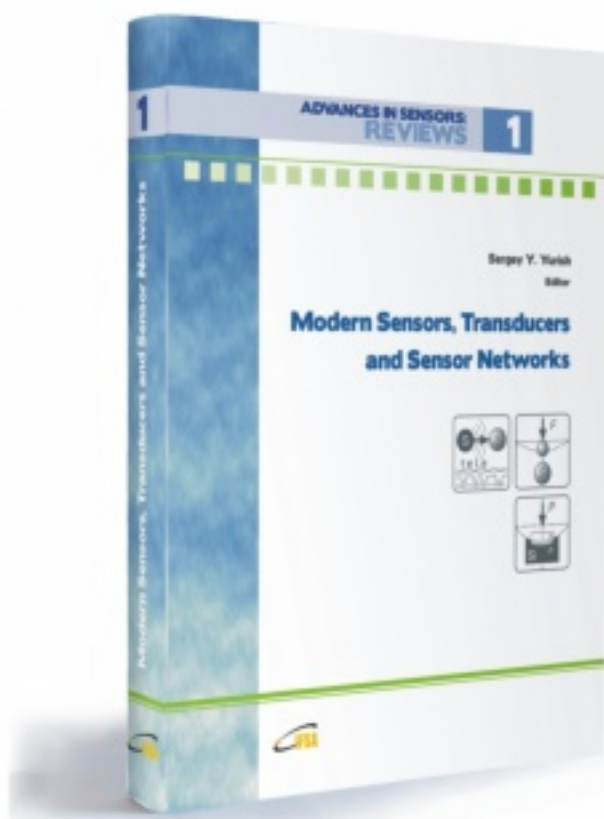

Modern Sensors, Transducers and Sensor Networks is the first book from the Advances in Sensors: Reviews book Series contains dozen collected sensor related state-of-the-art reviews written by 31 internationally recognized experts from academia and industry.

Built upon the series Advances in Sensors: Reviews - a premier sensor review source, the *Modern Sensors, Transducers and Sensor Networks* presents an overview of highlights in the field. Coverage includes current developments in sensing nanomaterials, technologies, MEMS sensor design, synthesis, modeling and applications of sensors, transducers and wireless sensor networks, signal detection and advanced signal processing, as well as new sensing principles and methods of measurements.

Modern Sensors, Transducers and Sensor Networks is intended for anyone who wants to cover a comprehensive range of topics in the field of sensors paradigms and developments. It provides guidance for technology solution developers from academia, research institutions, and industry, providing them with a broader perspective of sensor science and industry.

Order online:

http://sensorsportal.com/HTML/BOOKSTORE/Advance_in_Sensors.htm



www.sensorsportal.com